

A distributed multi-access computer network.

Proposals are made for a computer communications network that allows multi-access to numerous and diverse computing resources in a simple and efficient way. The scope and operation of this network scheme is probably best illustrated by example.

The basic structure of the network consists of a single coaxial cable up to 2Km in length along which all communications take place. Data passes up and down this cable at a fixed rate for a particular network implementation. This can be as high as 8 megabaud. Attached to this cable by 'T' pieces are up to 1024 stations that provide data interfaces to a computing resource. This is illustrated in figure 1.

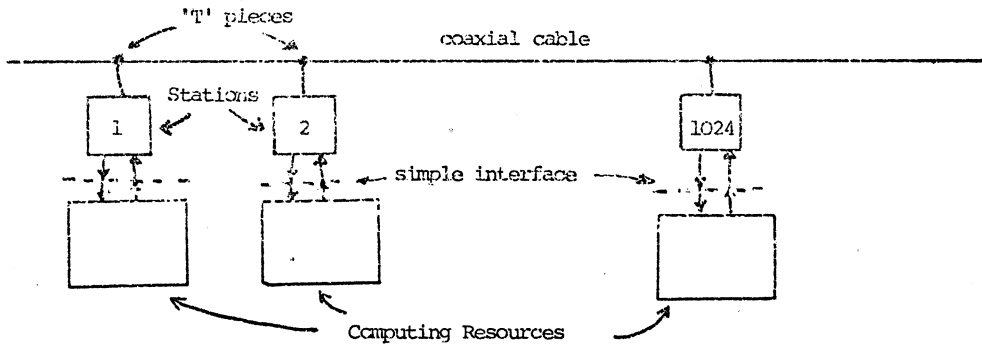

figure 1.

The network operates by broadcasting a variable length packet of information which is then "heard" by all the stations connected to the net. This is copied from the network by a destination station which selects the packet according to the address that was then put onto the net as a header by the source station. Note that control is completely distributed among the stations. A source station holds off transmission to any that may be in progress. If two or more stations claim the use of the network at the

same time a packet collision is detected and the transmission aborted. The colliding stations generate random re-transmission intervals to avoid repeated collisions, the mean of these intervals being a function of the collision history. This is designed to keep the network utilization near the optimum with a changing network load.

How then could this network be used? Consider a University Department with the following computational needs.

1. Computer control and collection of data from experiments
2. Simple teaching of programming
3. Special peripherals i.e. to output to a colour printer and input from a photo scanner
4. Intermittent need for access to package programs and/or substantial processing power.

Using the multi-access network already described these needs might be met by the hardware configuration shown in figure 2. The 2Km length of the network allows any of the computing resources to be located in convenient parts of the department such as laboratories and tutorial rooms. The obvious component missing from this configuration is a means of performing the substantial processing and use of packages. It is assumed (for the present) that this can be done by access via the GPO line to a service specializing in the Department's needs. As arranged the lab microprocessors could list on the line printer or plot on the plotter. Downline loading of programs from the 11/34 to the micros means that these systems could be minimal to the extent of their control function. (For example the Intel 8084 with integral 25Kb₂ ADC could be used).

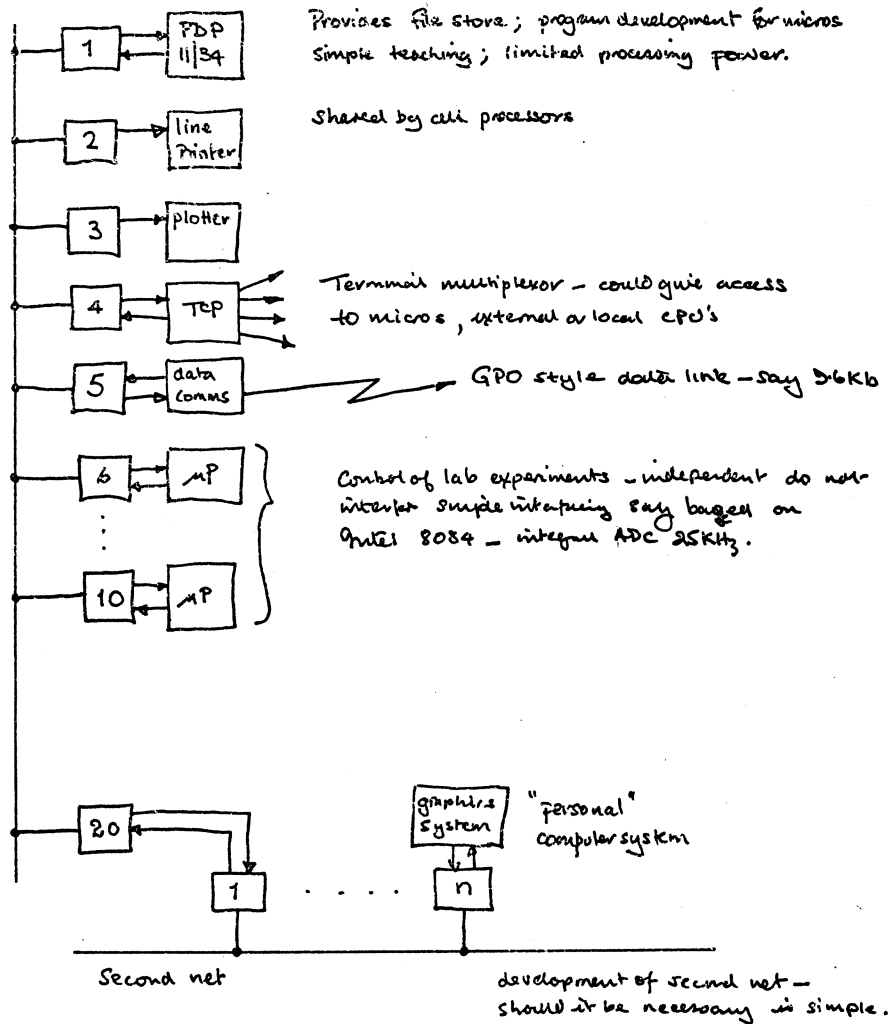

A Departmental Computing System.

Figure 2

Several comments are in order. First, the multi-access function provided by the network could be provided by a machine running a multi-process system. The line printer, plotter, external data communications and laboratory experiments could be controlled through this system. This might not be ideal since the function of one would effect the other needs. The system would be complex with high system overheads. This is essentially the approach of the centralized computer system allocating its processing power to meet a diverse set of computational needs. This approach has several difficulties.

1. Quite a large machine is needed to provide even a minimum of function.
2. It is quite expensive to expand and is committed to a particular kind of machine for quite a long time.
3. As the diversity of requirement increases so does the complexity of the operating system. Implicit in this is a decrease in the computer power devoted to user needs.

The original argument that favoured the centralized approach was that basic computer power was expensive and that the most economic way to provide it was to buy (or rent) the largest system you could afford and share it. There are two reasons why this course need no longer be followed. First, processing power (as opposed to systems) are cheap. For example one company is about to announce a machine with the performance of 370/168 for about £60K. This could easily be connected into the kind of network proposed. Second, users needs are now much more diverse than can sensibly be provided by one or two central computer systems.

The alternative distributed network approach has a number of advantages;

1. Control of access to computing resource is similarly distributed.
2. It is easier to incorporate new and cheaper systems - such as personal computers, micros, special peripherals into this network.
3. It is easier to expand and build a hierarchy of networks - each semi-independent. This does not preclude some central network which could link departments and provide particular facilities. For example, high security archive, photo typesetting, laser printing, and access to national networks and other resources etc.
4. Better use is made of the increasing amount of departmental computing equipment.

Cost of a multiaccess Station

At present component costs I estimate that a network station will cost in the order of £400. This does not include the initial design cost but does include production design, providing twenty or more stations are built. Over the next two years I would expect the cost of a station to halve. The cost of coaxil is small, compared to these costs.

Concluding statement

I believe these proposals represents the likely style of computing within University Department for the 1980's.