

Vectrex™
GRAPHIC COMPUTER SYSTEM

Vectrex™
GRAPHIC COMPUTER SYSTEM

GCE™
A Milton Bradley Company

PART NO. 140016—0201 ART REV A

LIGHTS

APPLEMASTER™

GCE
A Milton Bradley Company

© General Consumer Electronics, Inc. 1983, Santa Monica, CA 90401. All Rights Reserved.
—A copyright protection is claimed on the program stored within the cartridge—

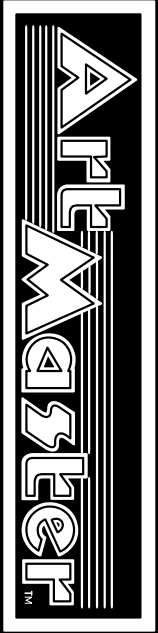

ART MASTER is a high performance, state-of-the-art experience that takes you into a world of art exploration you've never seen before! Finally, sketching comes of age...and your creativity comes to life!

Advanced electronics technology now makes it possible for you to design, draw, and animate your own art! Draw a bird. Then watch it fly! Sketch a train. Then send it speeding down the railroad tracks! Watch a flower blow in the wind or children walk to school. What you create...you can animate! You don't have to be a super-artist to use and enjoy Art Master. All you need is a sense of adventure, fun and a little imagination! We'll show you how to make Art Master the key that unlocks all the creativity you've always known you had!

VecTrex
GRAPHIC COMPUTER SYSTEM

Setting Up

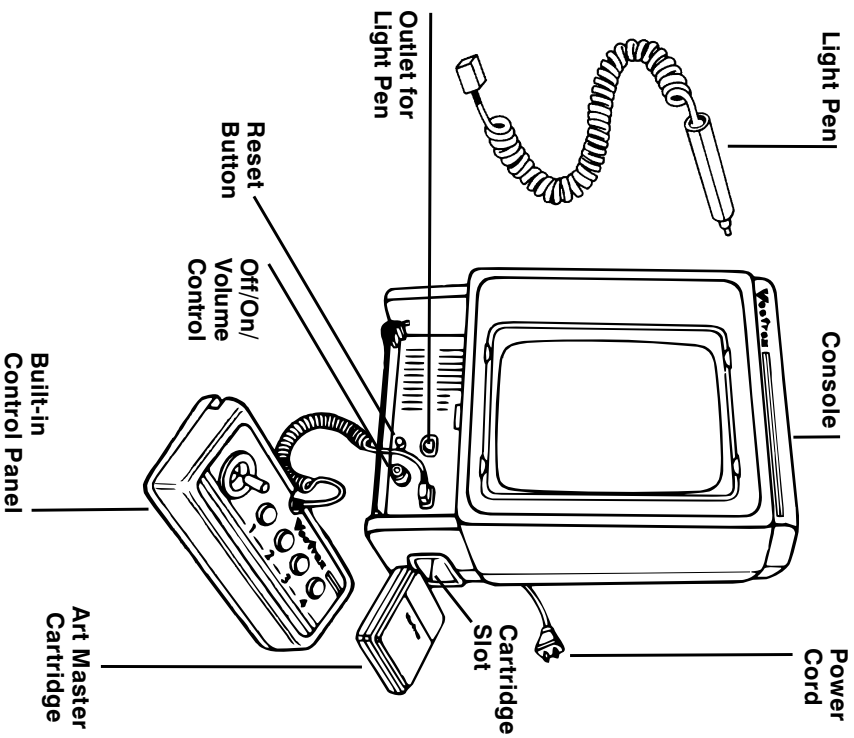

90 Day Limited Warranty

This Video Game Cartridge is warranted by General Consumer Electronics, Inc. to the original consumer purchaser in the U.S.A. for a period of 90 days from the original purchase date under normal use and service against defective workmanship and materials. ANY IMPLIED WARRANTIES ARE ALSO LIMITED IN DURATION TO THE NINETY (90) DAY PERIOD FROM THE ORIGINAL PURCHASE DATE. SOME STATES DO NOT ALLOW LIMITATIONS ON HOW LONG AN IMPLIED WARRANTY LASTS, SO THE ABOVE LIMITATION MAY NOT APPLY TO YOU.

This warranty is void if the GCE Video Game Cartridge has been damaged by accident, unreasonable use, neglect, misuse, abuse, improper service, modification, subject to commercial use or other causes not arising out of defects in workmanship or materials and is limited to electronic and mechanical parts contained in the cartridge.

GENERAL CONSUMER ELECTRONICS, INC. SHALL NOT BE LIABLE FOR LOSS OF USE OF THE VIDEO GAME CARTRIDGE OR OTHER INCIDENTAL OR CONSEQUENTIAL COSTS, EXPENSES OR DAMAGES INCURRED BY THE PURCHASER RESULTING FROM BREACH OF ANY EXPRESS OR IMPLIED WARRANTIES ON THE VIDEO GAME CARTRIDGE. SOME STATES DO NOT ALLOW THE EXCLUSION OR LIMITATION OF INCIDENTAL OR CONSEQUENTIAL DAMAGES, SO THE ABOVE LIMITATION OR EXCLUSION MAY NOT APPLY TO YOU.

During the warranty period, if found to be defective due to workmanship or materials, the GCE Video Game Cartridge will at the option of General Consumer Electronics, Inc. be repaired or replaced with a new or reconditioned GCE Video Game Cartridge without charge for parts or labor when returned by Purchaser with proof of purchase date, shipped prepaid to General Consumer Electronics, Inc. at the following address:

General Consumer Electronics, Inc.

233 Wilshire Boulevard
Santa Monica, California 90401

In the event that your GCE Video Game Cartridge is replaced, the warranty on the replacement will be ninety (90) days from the date of its return to you.

Example

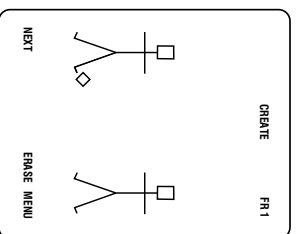

Frame 1

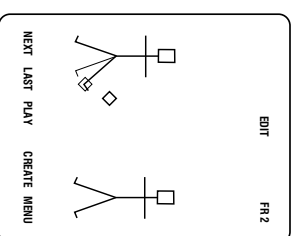

Frame 2

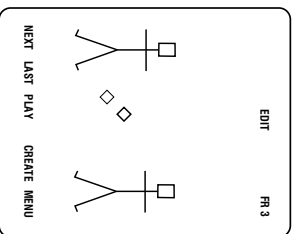

Frame 3

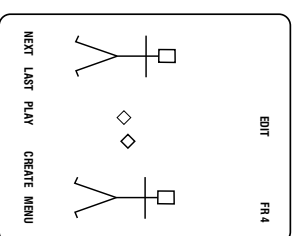

Frame 4

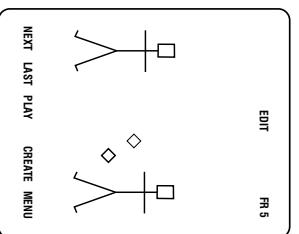

Frame 5

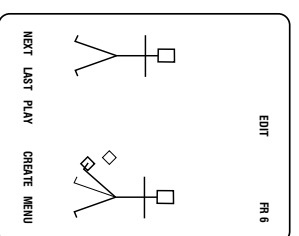

Frame 6

Setting Up

- Make sure the console power cord is plugged into a 120 volt AC 60 cycle electrical outlet.
- Check to be sure the plug for the built-in control panel is firmly seated in the control panel outlet on the right.
- Plug the Vectrex Light Pen into the outlet marked '2nd Player' (to the left of where the control panel is plugged in).
- MAKE SURE THE CONSOLE IS TURNED OFF BEFORE INSERTING THE CARTRIDGE. Insert the ART MASTER cartridge into the cartridge slot with the label side up. Be sure it is firmly inserted to the guideline marked on the cartridge.
- Turn the OFF/ON/VOLUME CONTROL to the ON position (clockwise). You will see the Vectrex title for a few seconds, then the ART MASTER title, followed by the Menu.
- Adjust the volume control to the desired listening level.
- IMPORTANT—Adjust the BRIGHTNESS CONTROL (on back of console) so that the white dot in the center of the screen just barely disappears. If the brightness is too dim, the Light Pen will not provide maximum performance

How to Play

There are three separate functions on the Art Master cartridge — SKETCH, CONNECT and ANIMATE. We'll take you through each function and work with you on some simple exercises. After you've learned the basics, the rest is up to you! Ready? Your art adventure is about to begin!

The Menu

After the Vectrex overture plays, a Menu listing all three functions of the Art Master cartridge will appear on your screen.

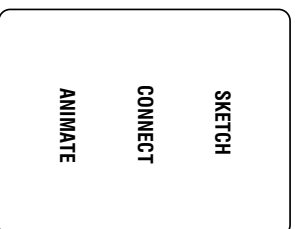

To make a selection, point the Light Pen at the appropriate word. The other two words will disappear and your chosen function will begin. The following sections of this instruction book will explain in detail how the three Menu selections work.

Animate Controls

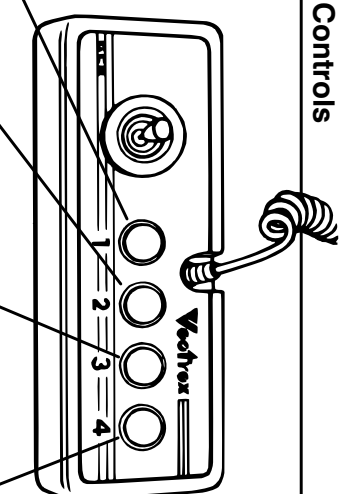

CREATE MODE

① Dot
Press to place a dot on the screen which will be the beginning point of a line. Also press to move "+" to a new point.

② Line
Press to form a straight line that begins at the dot.

③ Select/Move
Press to move your "active dot" around the screen. Also press while aiming at "NEXT" to enter Edit mode, or at "ERASE" to erase entire screen, or at "MENU" to return to the main Menu.

④ Remove
Press to remove unwanted lines.

EDIT MODE

① Foreground
Press to clear words at bottom of screen. This will reduce any "flicker" in the drawing. Press again for words to reappear.

③ Select/Move
Press to move a point and all lines connected to the point.

④ Background
Press to see "shadow" of your previous frame. Press again to remove the "shadow".

PLAY MODE

① Exit
Press to return to Edit mode.

② Exit
Press to return to Edit mode.

③ Slow
Press to play back your animation slowly. Each time you press it, the animation slows a little more.

④ Fast
Press to play back your animation quickly. Each time you press it, the animation will speed up a little more.

this play mode, you can speed up the animation by pressing Button 4 one or more times... or slow it down by pressing Button 3 one or more times.

Pressing Buttons 1 or 2 will return you to the "Edit" mode. You can go backwards or forwards to any frame to re-edit that frame by aiming the Light Pen at "LAST" or "NEXT" and pressing Button 3 one or more times.

To return to the "CREATE" mode or the main Menu at any time, aim the Light Pen at the appropriate word at the bottom of the screen and press Button 3.

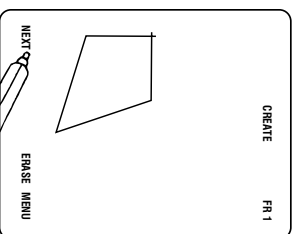

To advance to the next frame, aim pen at "NEXT" and press Button 3.

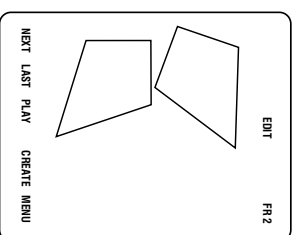

Press Button 4 to see a "shadow" of the previous frame.

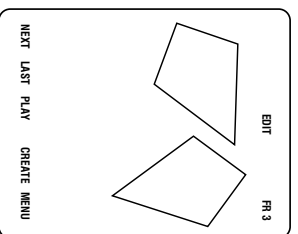

Continue to animate your figure in Frame 3...

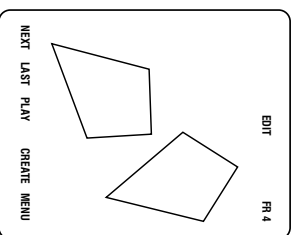

...in Frame 4 and beyond!

SKETCH

To enter the "SKETCH" mode, point your Light Pen at the word "SKETCH" when the Menu appears on your screen. The other two Menu items will disappear. In the SKETCH mode you'll be able to create virtually anything you want — fill up the entire screen or just a portion of it.

To start sketching, aim the Light Pen at the "+" symbol on the screen. Using your Light Pen, move the "+" to your desired starting position.

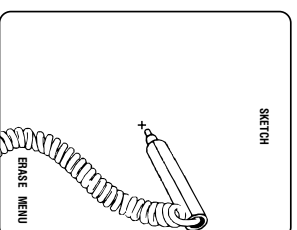

Aim Light Pen at desired starting position.

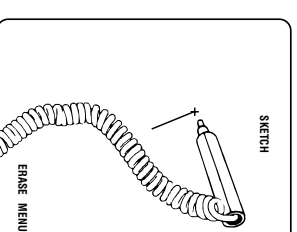

Press and hold Button 1 and move Light Pen to start drawing.

Draw Lines

To draw lines, press and hold Button 1 on the control panel while you move the "+" around the screen with your Light Pen. The slower you draw, the easier it will be to create curved lines. To draw another figure or object on a different part of the screen, release Button 1 and move the "+" with your Light Pen to a different starting position. Then press and hold Button 1 again as you draw the second figure.

Remember to keep the Light Pen close to the screen or touching the screen. If you move the Light Pen too far away from the surface of the screen, you will see a large burst of light (like a spider web) and the Light Pen will not operate properly.

While sketching, you may hear a "beep" tone. This will tell you that you have only ten lines left to draw before you've used all the available vectors... so finish your creation quickly!

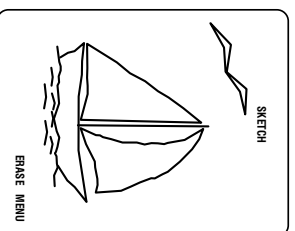
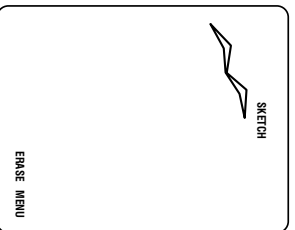

Strrrrrstretch Your Imagination...

Move the "+" with your Light Pen anywhere on the screen — this will be your starting point. Now press and hold Button 2 and move the Light Pen around the screen... watch your line stretch and pull to all directions just like a rubber band! Release Button 2 when your straight line is at the desired location and is the desired length.

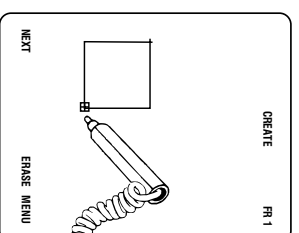
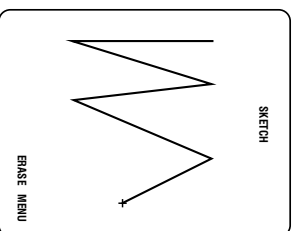

Aim pen at any point.

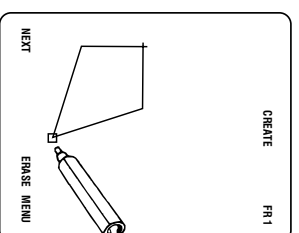

Press Button 3 and move point with pen.

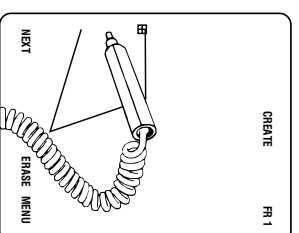

To remove a line, aim pen at line and press Button 4.

Animating the Figure

To advance to Frame 2 and begin animating your basic figure, aim the Light Pen at the word "NEXT" at the bottom of the screen and press Button 3. You will also hear a "beep" to indicate that you have advanced to the next frame.

Once in Frame 2, you can alter your figure in any desired way using the same method described in "Adjusting the Figure". If you wish to see the previous frame's figure, press Button 4. You can remove the previous frame's figure by pressing Button 4 again.

You can also remove the words from the bottom of the screen by pressing Button 1. This will reduce any "flicker" in your drawing. Pressing Button 1 again will cause the words to reappear.

Once you have the figure adjusted as desired in Frame 2, you can advance to Frame 3 and beyond using the same procedure. There are 9 frames available for your animation, but you need not use all of them. You may animate on as few as two frames.

Once all the desired frames are drawn, aim the Light Pen at the word "PLAY" at the bottom of the screen and press Button 3 to see your animation in action. Once in

To create your figure, use Buttons 1 and 2 to define starting points and draw lines. To close a figure, aim the Light Pen at a previously defined point — when it is detected, a square will appear around the point. Then press Button 2. You can also move the “+” by aiming the Light Pen at your desired new starting point and pressing Button 1.

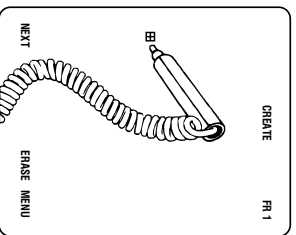

Press Button 1 at desired starting point:

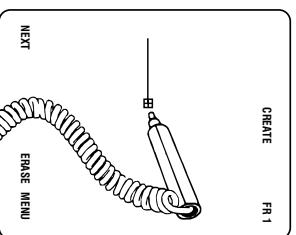

Press Button 2 to draw line starting at first point:

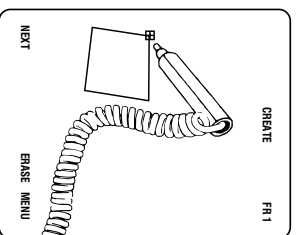

To close figure, aim pen at existing point and press Button 2.

Adjusting the Figure

You can make adjustments to your basic figure before beginning to animate it. To make adjustments, aim the Light Pen at any point on your figure. When the point is detected, a square will appear around the point. Press Button 3 and then move the point with the Light Pen, which will also move all lines connected to that point (like a “rubber band” effect). Release Button 3 when that point is in the desired location. Continue to adjust your figure in this manner until it is completed to your satisfaction. To remove a line, aim the Light Pen at the line and it will appear slightly brighter. Then press Button 4 to remove the line.

Make Fans

Press and hold Button 4 and move your Light Pen in a circular motion to form a “fan” of lines around a central point. Go left or right... up or down. It makes no difference which way you move your Light Pen. Form flower tops, cosmic explosions, stars... dozens of other creations.

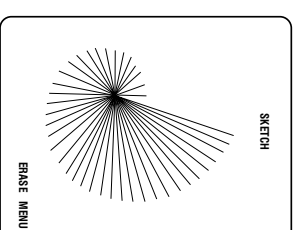

To erase your creations and begin again, simply point your Light Pen at the word “ERASE” at the bottom of the screen and press Button 3. To return to the Menu for other Art Master functions, point the Light Pen at the word “MENU” and press Button 3.

Sketch Controls

① **Draw**—Press and hold while moving Light Pen.

② **Stretch**—Press while moving Light Pen to draw a straight line. Release Button when line is desired length.

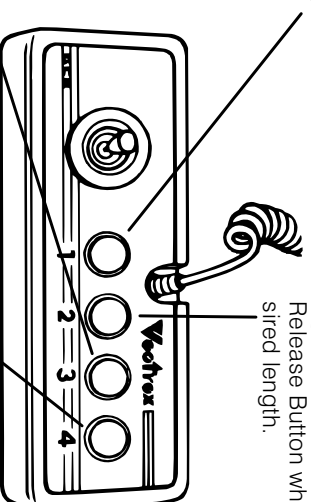

③ **Erase/Menu**—Press while placing Light Pen over “ERASE” or “MENU” “ERASE” clears the screen. “MENU” returns you to the Menu.

④ **Fan**—Press while moving Light Pen in a circle to create a “fan” effect.

CONNECT

To enter the "CONNECT" mode call up the Menu by placing the Light Pen over the word "Menu", and then press Button 3. When the Menu appears, aim the Light Pen over the word "CONNECT".

Now you're off on a totally new art experience! Your drawings appear on the screen in a series of unconnected dots — and all with the simple swirl of your Light Pen! Write words, draw spaceships, faces or scenes — then just push Button 4 and watch your dots suddenly connect and change to lines!

This mode simply allows you to draw graphics in a series of dots rather than in full lines, as in the "SKETCH" mode. Press and hold Button 1 to draw dots or Button 2 to draw straight lines (i.e., a dot at either end of a straight line). Release the buttons to move the "+" to another position on the screen. Press Button 4 to connect the dots. Pressing Button 4 again will allow you to return to dots.

You may want to design a pattern or code and create it in dots. Then ask a friend to guess what you've drawn. Connect them together by pressing Button 4 to see if your friend got it right! Every time you push Button 4, you change your drawing, sketch or design from dots to lines and then back again.

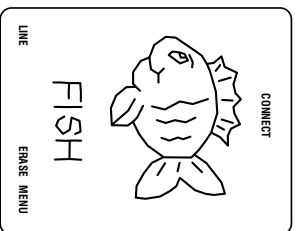
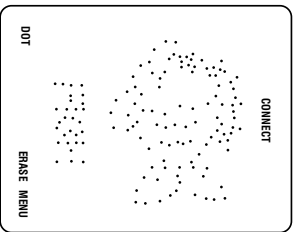

8

Connect Controls

- ① **Draw**—Press and hold while moving Light Pen to create dots.
- ② **Stretch**—Press while moving Light Pen to draw a straight line (dot at either end). Release Button when line is desired length.
- ③ **Erase/Menu**—Press while placing Light Pen over "ERASE" or "MENU". "ERASE" clears the screen. "MENU" returns you to the Menu.
- ④ **Connect**—Press to connect your dot pattern. Press again to return to dots.

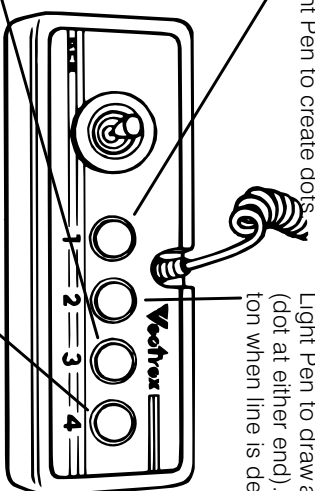

ANIMATE

Living art... moving designs... swirling drawings! When you use your Art Master in the "ANIMATE" mode, you really make your artwork a moving experience!

Draw an animal... and make it move! Sketch a centipede... and watch it run! Draw soldiers... and march them across the screen! Become a pioneer in the new Space Age frontier!

You have up to 31 lines in this mode to draw graphics... then animate them!

Creating the Basic Figure

To draw your initial figure (which you will later animate), aim the Light Pen at your desired starting point and press Button 1 to get a dot and the "+" to appear. To create a line starting at this dot, aim the Light Pen at another point and press Button 2.

9