

# Vectrex - Repair manual

by Nicolas Weill

with the assistance of Flore Netter

Special thanks to Pascal, Jeremy and Gérard for their Vectrex

Review by the members of the MO5 association

Reviewed on Mars 27, 2023

\*Please send your comments, corrections or translation proposals on the  
Github <https://github.com/Guimli/Vectrex-Repair-Manual>

# Contents

<b>1</b>	<b>Precaution</b>	<b>6</b>
<b>2</b>	<b>Recurring failure</b>	<b>6</b>
2.1	No sound and no image . . . . .	6
2.2	No sound and white point . . . . .	6
2.3	Presence of sound, but white point . . . . .	6
2.4	Other image problems . . . . .	7
<b>3</b>	<b>Repair methodologyn</b>	<b>8</b>
<b>4</b>	<b>Schematic</b>	<b>8</b>
4.1	PowerBoard . . . . .	8
4.2	LogicBoard . . . . .	10
4.3	CRT Board . . . . .	12
<b>5</b>	<b>Oscilloscope Readings</b>	<b>14</b>
5.1	IC201 - 2363 . . . . .	14
5.1.1	Pin 1 (VPP) . . . . .	14
5.1.2	Pin 2 to 10, 21, 23, 24,25 (A0 to A12) . . . . .	15
5.1.3	Pin 11 to 13 and 15 to 19 (D0 to D7) . . . . .	15
5.1.4	Pin 14 (GND) . . . . .	15
5.1.5	Pin 20 ( $\overline{\text{ChipEnable}}$ ) . . . . .	15
5.1.6	Pin 22 ( $\overline{\text{OutputEnable}}$ ) . . . . .	15
5.1.7	Pin 27 ( $\overline{\text{PGM}}$ ) . . . . .	15
5.1.8	Pin 28 (VCC) . . . . .	15
5.2	IC202 - 74LS00 . . . . .	16
5.2.1	Pin 1 et 2 (Gate 1 input - Enable) . . . . .	16
5.2.2	Pin 3 (Gate 1 output - $\overline{\text{Enable}}$ ) . . . . .	16
5.2.3	Pin 4 et 5 (Gate 2 input - A14 et A15) . . . . .	16
5.2.4	Pin 6 (Gate 2 output - $\overline{\text{ROMS}}$ ) . . . . .	16
5.2.5	Pin 7 (GND) . . . . .	17
5.2.6	Pin 8 (Gate 3 output - $\overline{\text{ROMOE}}$ ) . . . . .	17
5.2.7	Pin 9 (Gate 3 input - Enable) . . . . .	17
5.2.8	Pin 10 (Gate 3 input - A13) . . . . .	18
5.2.9	Pin 11 (Gate 4 output) . . . . .	19
5.2.10	Pin 12 (Gate 4 input - A11) . . . . .	20
5.2.11	Pin 13 (Gate 4 input - Enable) . . . . .	20
5.2.12	Pin 14 (VCC) . . . . .	20
5.3	IC203 - 74LS32 . . . . .	21
5.3.1	Pin 1 (Gate 1 input - $\overline{\text{Enable}}$ ) . . . . .	21
5.3.2	Pin 2 (Gate 1 input - A15) . . . . .	21
5.3.3	Pin 3 (Gate 1 output - $\overline{\text{CARTS}}$ ) . . . . .	22
5.3.4	Pin 4 (Gate 2 input - $\overline{\text{RW}}$ ) . . . . .	22
5.3.5	Pin 5 (Gate 2 input - $\overline{\text{RAMS}}$ ) . . . . .	22

5.3.6	Pin 6 (Gate 2 output - RAM_R $\overline{W}$ )	23
5.3.7	Pin 7 (GND)	23
5.3.8	Pin 8 (Gate 3 sortie - RAMS)	24
5.3.9	Pin 9 (Gate 3 input)	24
5.3.10	Pin 10 (Gate 3 input - I $\overline{OS}$ )	24
5.3.11	Pin 11 (Gate 4 output - I $\overline{OS}$ )	25
5.3.12	Pin 12 (Gate 4 input - ROMS)	25
5.3.13	Pin 13 (Gate 4 input - A13)	26
5.3.14	Pin 14 (VCC)	26
5.4	IC204, IC205 - 2114	27
5.4.1	Pin 1 à 7, 15, 16, 17 (A0 à A9)	27
5.4.2	Pin 8 (ChipSelect)	27
5.4.3	Pin 9 (GND)	27
5.4.4	Pin 10 (WriteEnable)	27
5.4.5	Pin 11 à 14 (DA à DD)	27
5.4.6	Pin 18 (VCC)	27
5.5	IC206 - 68A09	28
5.5.1	Pin 1 (GND)	28
5.5.2	Pin 2 (NMI)	28
5.5.3	Pin 3 (IRQ)	28
5.5.4	Pin 4 (FIRQ)	28
5.5.5	Pin 7 (VCC)	28
5.5.6	Pins 8 à 21 (A0 à A13)	29
5.5.7	Pins 22 et 23 (A14 et A15)	30
5.5.8	Pins 24 à 31 (D0 à D7)	31
5.5.9	Pin 32 (R $\overline{W}$ )	32
5.5.10	Pin 33 (DMA)	32
5.5.11	Pin 34 (Enable)	33
5.5.12	Pin 35 (Q)	34
5.5.13	Pin 36 (MReady)	34
5.5.14	Pin 37 (Reset)	34
5.5.15	Pin 38 (ExTal)	35
5.5.16	Pin 39 (XTal)	36
5.5.17	Pin 40 (Halt)	36
5.6	IC207 - 6522	37
5.6.1	Pin 1 (GND)	37
5.6.2	Pin 2 à 9 (PA0 à PA7)	37
5.6.3	Pin 10 (PB0)	37
5.6.4	Pin 11 et 12 (PB1 & PB2)	37
5.6.5	Pin 13 (PB3)	38
5.6.6	Pin 14 (PB4)	39
5.6.7	Pin 15 (PB5)	40
5.6.8	Pin 16 (PB6)	40
5.6.9	Pin 17 (PB7)	41
5.6.10	Pin 19 (CB2)	42
5.6.11	Pin 20 (VCC)	42

5.6.12	Pin 21 ( $\overline{\text{IRQB}}$ )	42
5.6.13	Pin 22 ( $\overline{\text{RWB}}$ )	42
5.6.14	Pin 23 ( $\overline{\text{CS2B}}$ )	42
5.6.15	Pin 24 (CS1)	42
5.6.16	Pin 25 (Enable)	43
5.6.17	Pin 26 à 33 (D0 à D7)	43
5.6.18	Pin 34 ( $\overline{\text{Reset}}$ )	43
5.6.19	Pin 35 et 38 (A0 à A3)	43
5.6.20	Pin 39 (CA2)	43
5.6.21	Pin 40 (CA1)	43
5.7	IC208 - AY-3-8912	44
5.7.1	Pin 1, 4 et 5 (CHC, CHB, CHA)	44
5.7.2	Pin 3 (VCC)	44
5.7.3	Pin 6 (GND)	44
5.7.4	Pin 7 à 14 (IOA0 à IOA7)	44
5.7.5	Pin 15 (Clock)	44
5.7.6	Pin 16 ( $\overline{\text{Reset}}$ )	44
5.7.7	Pin 17 (A8)	44
5.7.8	Pin 18 (BDir)	44
5.7.9	Pin 19 (BC2)	44
5.7.10	Pin 20 (BC1)	44
5.7.11	Pin 21 à 28 (DA0 à DA7)	44
5.8	IC301 - MC-1408P8	45
5.8.1	Pin 1 (Range / Not connected)	45
5.8.2	Pin 2 (GND)	45
5.8.3	Pin 3 (VEE)	45
5.8.4	Pin 4 ( $I_{\text{OUT}}$ )	45
5.8.5	Pin 5 à 12 (DA0 à DA7)	45
5.8.6	Pin 13 (VCC)	45
5.8.7	Pin 14 ( $V_{\text{REF+}}$ )	45
5.8.8	Pin 15 ( $V_{\text{REF-}}$ )	45
5.8.9	Pin 16 (Compensation)	45
5.9	IC302 - 4052B	46
5.9.1	Pin 1, 2, 4 et 5 (Y channels In/Out)	46
5.9.2	Pin 3 (Common Y)	46
5.9.3	Pin 6 (Inhibit)	46
5.9.4	Pin 7 (VEE)	47
5.9.5	Pin 8 (VSS)	47
5.9.6	Pin 9 et 10 (Select A et B)	47
5.9.7	Pin 11 (X Channel 3)	47
5.9.8	Pin 12 (X Channel 0)	48
5.9.9	Pin 13 (Common X)	49
5.9.10	Pin 14 (X Channel 1)	49
5.9.11	Pin 15 (X Channel 2)	50
5.9.12	Pin 16 (VDD)	50
5.10	IC303 - LF347	51

5.10.1	Pin 1 (Output)	51
5.10.2	Pin 2 (Input)	52
5.10.3	Pin 3 (Input)	52
5.10.4	Pin 4	52
5.10.5	Pin 5 (Input)	52
5.10.6	Pin 6 (Input)	52
5.10.7	Pin 7 (Output)	53
5.10.8	Pin 8 (Output)	54
5.10.9	Pin 9 (Input)	54
5.10.10	Pin 10 (Input)	54
5.10.11	Pin 11	54
5.10.12	Pin 12 (Input)	54
5.10.13	Pin 13 (Input)	55
5.10.14	Pin 14 (Output)	56
5.11	IC304 - LF353	57
5.11.1	Pin 1 (Output)	57
5.11.2	Pin 2 (Input)	57
5.11.3	Pin 3 (Input)	57
5.11.4	Pin 4	57
5.11.5	Pin 5 (Input)	58
5.11.6	Pin 6 (Input)	58
5.11.7	Pin 7 (Output)	58
5.11.8	Pin 8	58
5.12	IC305 - 4066B	59
5.12.1	Pin 1 (Input)	59
5.12.2	Pin 2 (Output)	60
5.12.3	Pin 3 (Output)	61
5.12.4	Pin 4 (Input)	62
5.12.5	Pin 5 (Input)	63
5.12.6	Pin 6 (Input)	64
5.12.7	Pin 7 (VSS)	64
5.12.8	Pin 8 (Input)	64
5.12.9	Pin 9 (Output)	65
5.12.10	Pin 10 (Output)	66
5.12.11	Pin 11 (Input)	67
5.12.12	Pin 12 (Input)	68
5.12.13	Pin 13 (Input)	69
5.12.14	Pin 14 (VDD)	69
5.13	J301 - Video Connector	70
5.13.1	Blue	70
5.13.2	Red	70
5.13.3	Yellow	71
5.14	J302 - Audio	73
5.14.1	Black	73

**6 Technical documentation and substitute components 74**

# 1 Precaution

## Electrical hazard



Vectrex consoles contain a cathode ray tube. High voltages are present in the electronic equipment, even after the console is turned off. Do not handle a Vectrex without the specific electrical knowledge required.

# 2 Recurring failure

## 2.1 No sound and no image

- Check the switch SW301. This switch has been known to seize over the years. It is then necessary to open the back, add some degreaser and activate the contacts to diffuse the degreaser. If necessary, use sandpaper on the contacts if you notice any oxidation.
- Check fuse F101. Replace the fuse if necessary. If the fuse blows systematically, the most frequent cases of short circuit are on components IC101 (LM340), IC102 (7905) and IC401 (LM379).

## 2.2 No sound and white point

- IC207 (PIA 6522) is the main cause of failures on the Vectrex console. Replacing it is always the first operation to be done.
- The absence of sound indicates that the processor, ROM, RAM and PIA assembly is not working properly. If the PIA has already been replaced unsuccessfully, the most likely cause is a corrupted IC201 ROM (2363).
- Case of multiple failures: It is possible that several failures interfere with the analysis. For example, a partial failure of switch SW301 could interrupt the -13V causing a white point. And a failure of the audio amplifier IC103 (LM386) could cause an absence of sound.

## 2.3 Presence of sound, but white point

- Check the presence of the voltages on J204 (+5V, -5V, -13V). The absence of -13V generates a white point and may indicate a problem with the switch SW301 or the zener diode DZ102.
- The most common cause of a white dot on the screen is a failure of IC207 (PIA 6522).

- There are many faults that can generate a white point. Refer to the scope readings to correct image/white point problems.

## 2.4 Other image problems

- Refer to the scope readings to correct image/white point problems.
- Following a capacitor replacement: vector undulation, buzzing louder than normal, main heatsink on the power supply board hotter than normal. This problem can occur due to the lack of a metallized hole on the C404 and C411 capacitors. Ensure that you have applied tin on both sides of the PCB for these capacitors. Check the continuity between the Vectrex ground and the corresponding pin of the capacitors.
- A rare but difficult to diagnose image problem may come from the J301 cable. The contacts inside are crimped and not soldered. It is therefore possible to see oxidation appear on the contacts or in the cable-contact junction. This problem is invisible from the outside and requires removing the contacts from the cable for inspection.
- Rare problem of image shifting during joystick movements: replace IC302 (CD4052D).

### 3 Repair methodology

An effective diagnostic approach is to divide the circuit into sections and perform a dichotomy analysis.

- Always start by checking the operation of switch SW301. This may be partially defective. The voltage levels will nevertheless be correct. But only one of the two coils of the secondary of the transformer T102 will be operated, generating wear and overheating of several elements of the power supply. This will cause wear and tear and overheating of several elements of the power supply, as well as a greater instability of the voltage levels. This will cause the image to vibrate.
- Check the voltage levels on connector J204.
- Check pins 3, 6, 9 and 10 of IC302 (4052B). If the signals from these pins are incorrect, then the problem is in the digital part of the LogicBoard (IC201 to IC208, IC301 and IC304).

### 4 Schematic

#### 4.1 PowerBoard



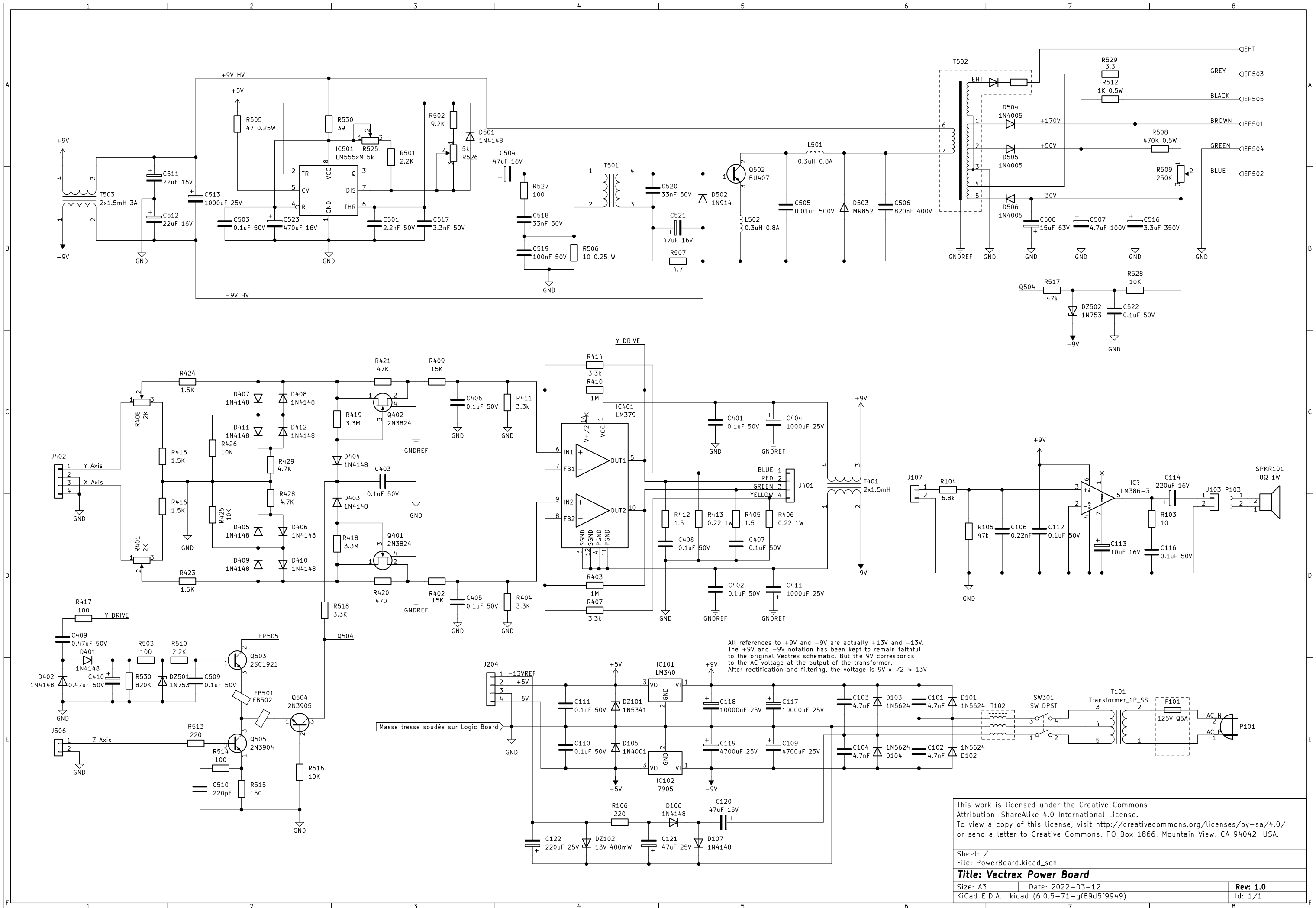

This work is licensed under the Creative Commons Attribution-ShareAlike 4.0 International License. To view a copy of this license, visit <http://creativecommons.org/licenses/by-sa/4.0/> or send a letter to Creative Commons, PO Box 1866, Mountain View, CA 94042, USA.

Sheet: /  
File: PowerBoard.kicad\_sch

**Title: Vectrex Power Board**

Size: A3	Date: 2022-03-12	Rev: 1.0
KiCad E.D.A. kicad (6.0.5-71-gf89d5f9949)		Id: 1/1

## 4.2 LogicBoard

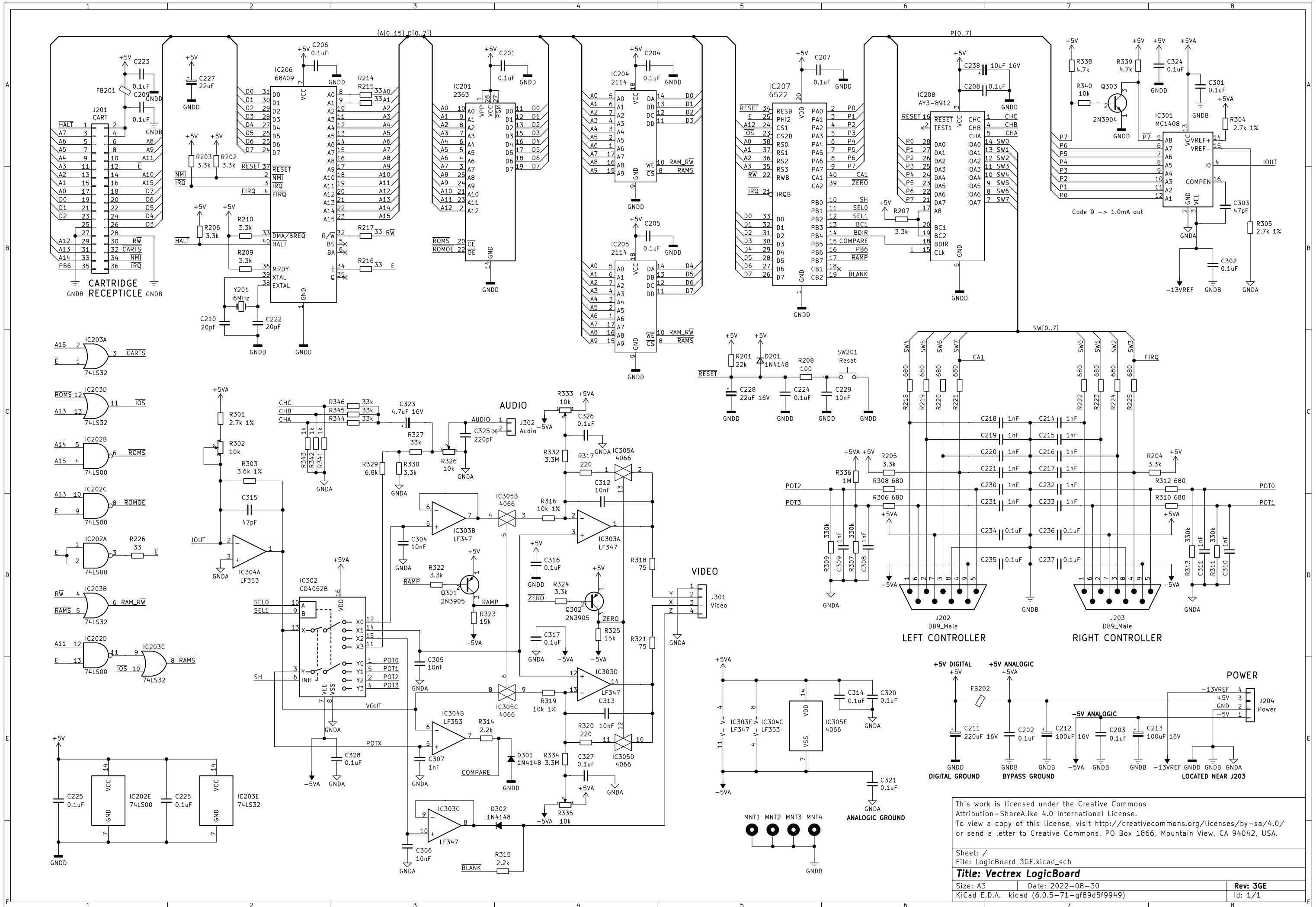

This work is licensed under the Creative Commons Attribution-ShareAlike 4.0 International License. To view a copy of this license, visit <http://creativecommons.org/licenses/by-sa/4.0/> or send a letter to Creative Commons, PO Box 1866, Mountain View, CA 94042, USA.

Sheet: /  
 File: LogicBoard 3GE.kicad\_sch  
**Title: Vectrex LogicBoard**  
 Size: A3 Date: 2022-08-30 Rev: 3GE  
 KiCad E.D.A. kicad (6.0.5-71-gf89d5f9949) Id: 1/1

### 4.3 CRT Board

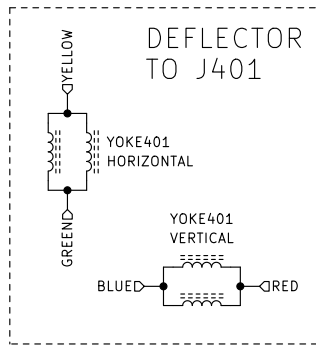
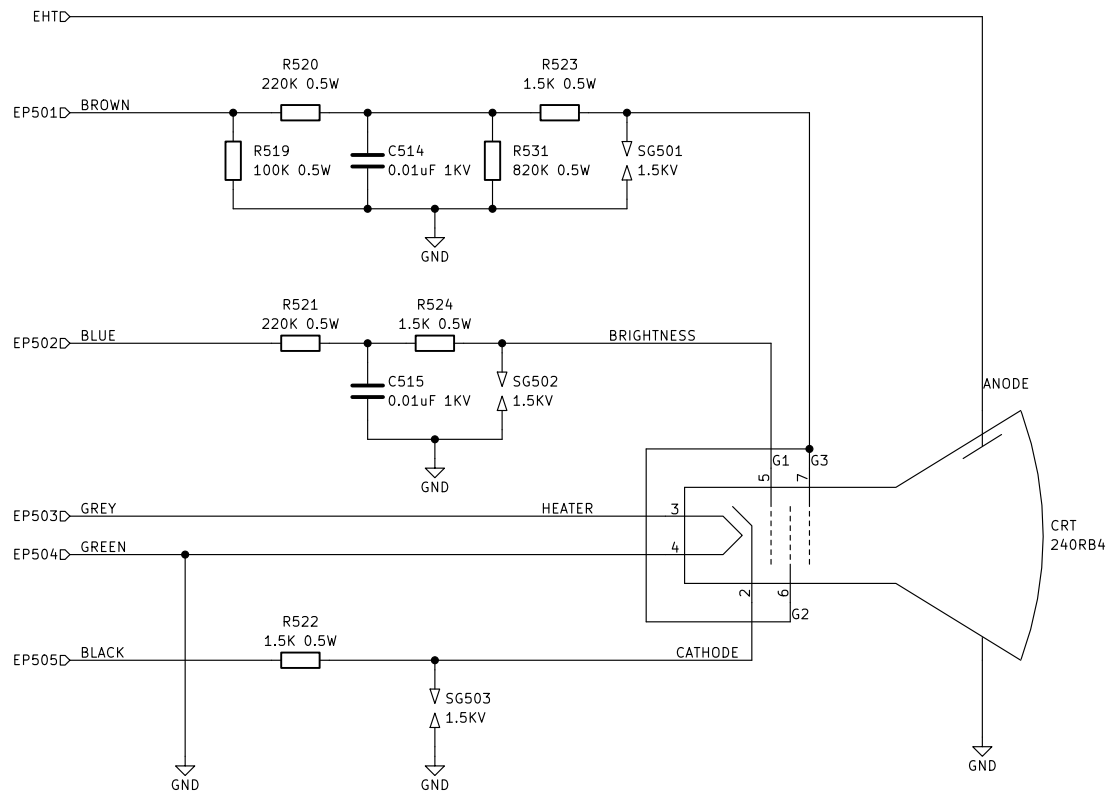

This work is licensed under the Creative Commons Attribution-ShareAlike 4.0 International License. To view a copy of this license, visit <http://creativecommons.org/licenses/by-sa/4.0/> or send a letter to Creative Commons, PO Box 1866, Mountain View, CA 94042, USA.

Sheet: /	
File: CRTBoard.kicad_sch	
<b>Title: Vectrex CRT Board</b>	
Size: A4	Date: 2022-03-12
KiCad E.D.A. kicad (6.0.0)	Rev: 1.0
	Id: 1/1

## 5 Oscilloscope Readings

Oscilloscope readings are sorted by component ID. Refer to the Diagnostic Methodology chapter for ...(to be done/in progress)

### 5.1 IC201 - 2363

**Description:** Internal ROM containing the initialization program of the Vectrex, as well as the Minestorm game.

A corruption of the ROM can be detected by a regular reset of the processor as in the oscilloscope reading below corresponding to one of the address pins of the processor:

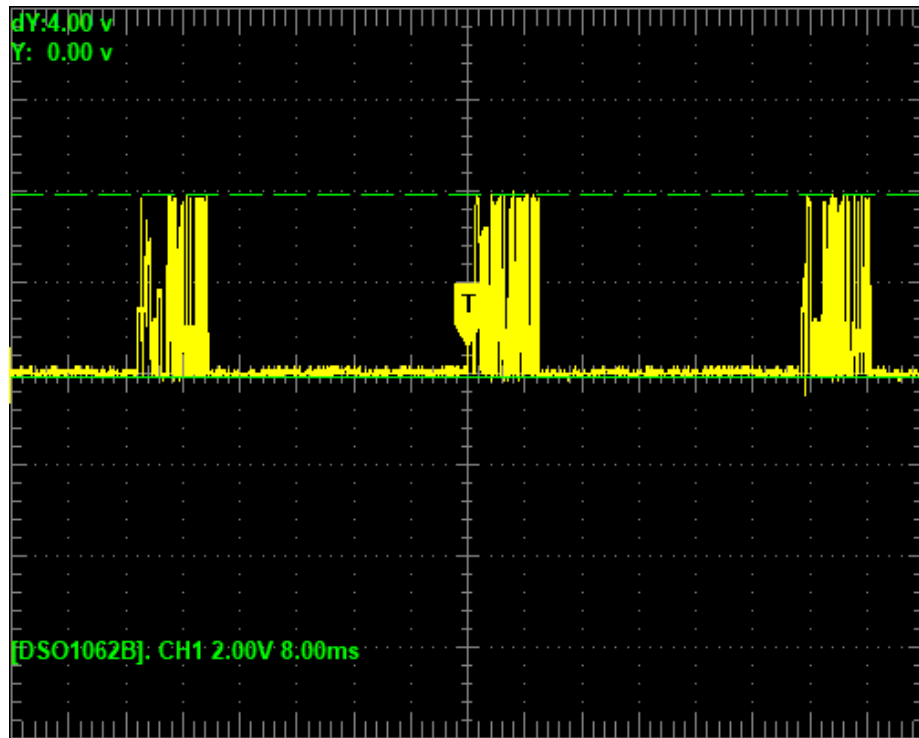

It is necessary to have another ROM already programmed to replace IC201. It is possible to replace the ROM with an EPROM of type 27C64.

Reading the ROM content in a compatible programmer must return checksum 7931, B796 or 7ADB. The different ROM versions are interchangeable in the different Vectrex versions. The most recent version, and therefore to be preferred, is the version whose checksum is 7ADB.

#### 5.1.1 Pin 1 (VPP)

Programming voltage. Connected to +5V logic.

**5.1.2 Pin 2 to 10, 21, 23, 24,25 (A0 to A12)**

See IC206 Pins 8 à 21 (A0 à A13).

**5.1.3 Pin 11 to 13 and 15 to 19 (D0 to D7)**

See IC206 Pins 24 à 31 (D0 à D7).

**5.1.4 Pin 14 (GND)**

Logical mass, 0V.

**5.1.5 Pin 20 ( $\overline{\text{ChipEnable}}$ )**

See IC202 Pin 6 (Gate 2 output -  $\overline{\text{ROMS}}$ ).

**5.1.6 Pin 22 ( $\overline{\text{OutputEnable}}$ )**

See IC202 Pin 8 (Gate 3 output -  $\overline{\text{ROMOE}}$ ).

**5.1.7 Pin 27 ( $\overline{\text{PGM}}$ )**

Used to program the PROM in the factory. Connected to +5V logic.

**5.1.8 Pin 28 (VCC)**

Power supply, +5V logic.

## 5.2 IC202 - 74LS00

**Description:** Quadruple NAND gate

### 5.2.1 Pin 1 et 2 (Gate 1 input - Enable)

Pins 1 & 2 are connected to pin 34 of the IC206 processor (pin Enable).  
See IC206 Pin 34 (Enable).

### 5.2.2 Pin 3 (Gate 1 output - $\overline{\text{Enable}}$ )

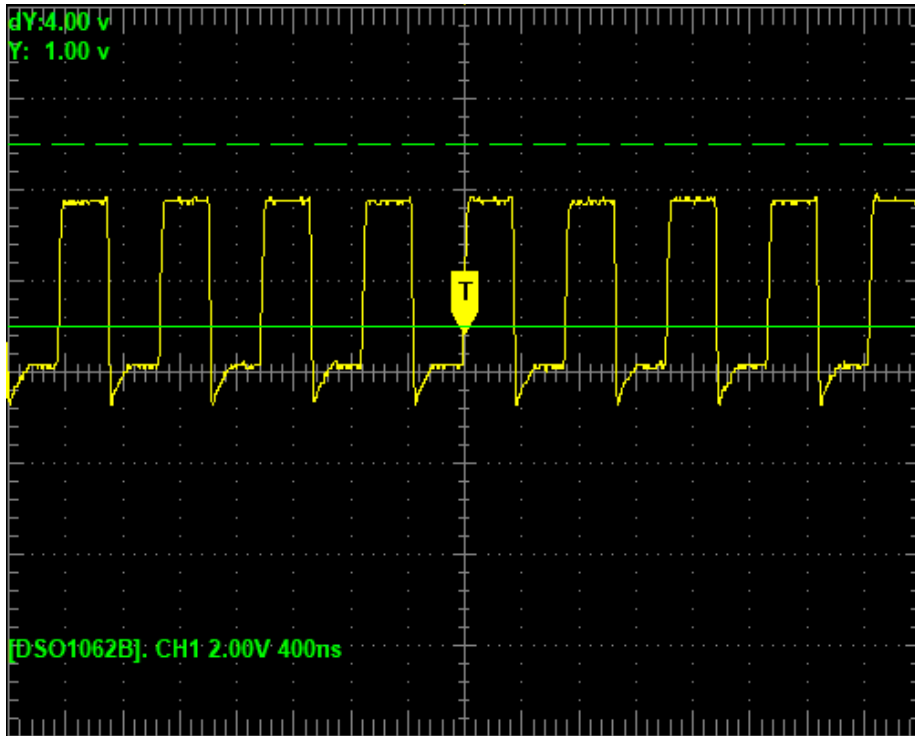

- If there is no signal, check pins 1 and 2 of IC202. If the signals are correct, replace IC202.

### 5.2.3 Pin 4 et 5 (Gate 2 input - A14 et A15)

See IC206 Pins 22 et 23 (A14 et A15).

### 5.2.4 Pin 6 (Gate 2 output - $\overline{\text{ROMS}}$ )

This pin is connected to the OE (Output Enable) pin of the IC201 ROM. It should always be at a voltage level of 0V unless you are using a game cartridge. If this is not the case, check pins 4 and 5 of IC202. Replace IC202 if necessary.



### 5.2.5 Pin 7 (GND)

Ground, 0V

### 5.2.6 Pin 8 (Gate 3 output - $\overline{\text{ROMOE}}$ )

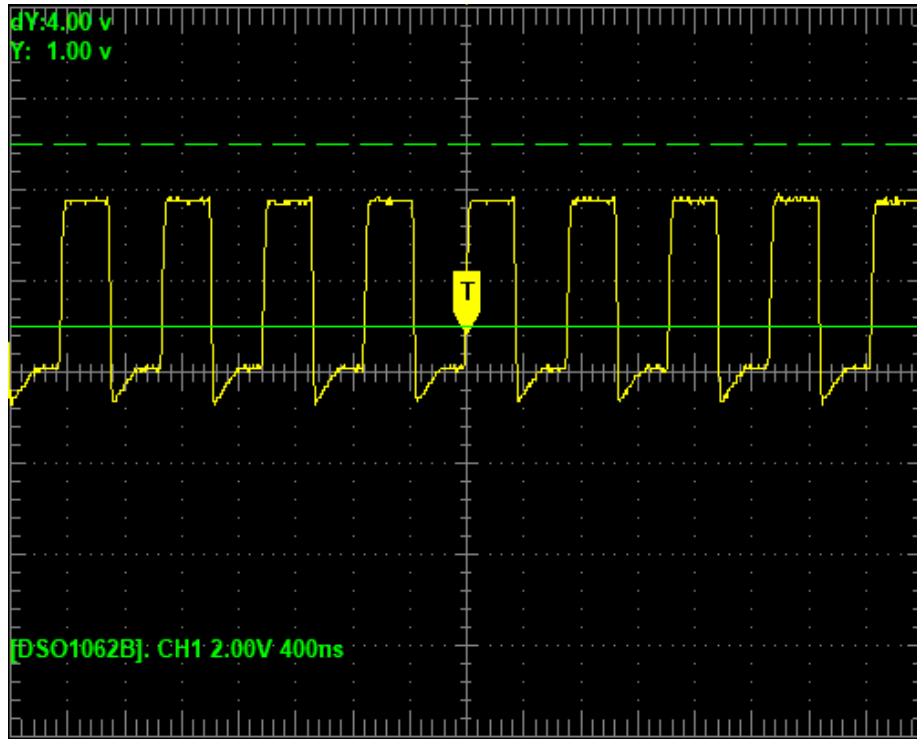

- If there is no signal, check the signal on pins 9 & 10 of IC202. If the signal on pins 9 & 10 is correct, replace IC202.

### 5.2.7 Pin 9 (Gate 3 input - Enable)

See IC206 Pin 34 (Enable).

- in 9 is connected to pin 34 of the IC206 processor (Enable pin). A lack of signal on this pin indicates a problem with the processor. Check R216, XTAL201, and replace the IC206 processor if necessary.

### 5.2.8 Pin 10 (Gate 3 input - A13)

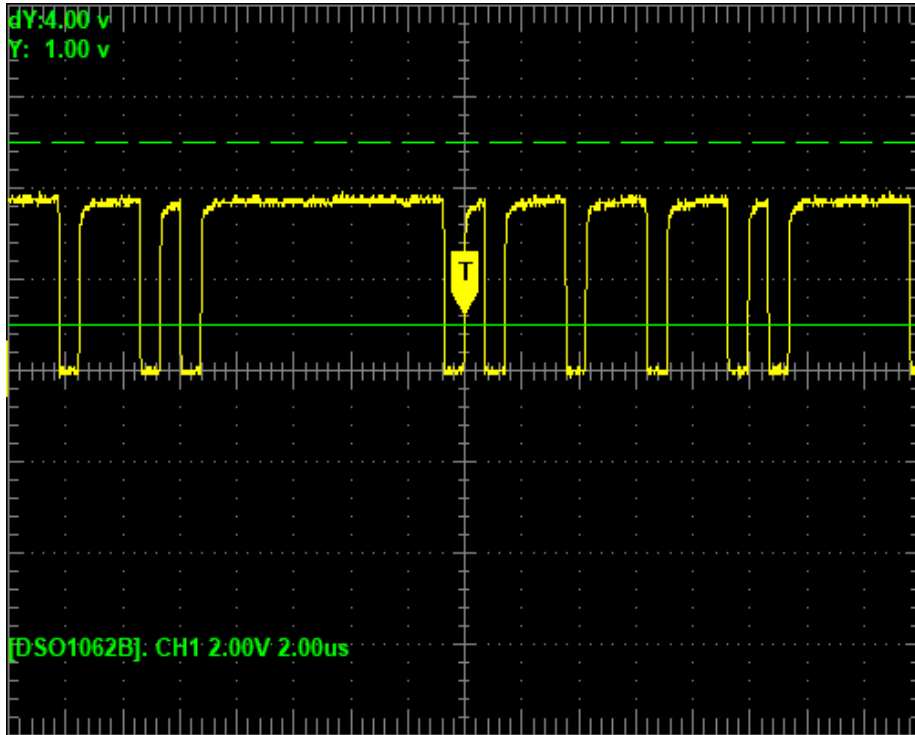

- If there is no signal, check the operation of IC206 and IC201.

### 5.2.9 Pin 11 (Gate 4 output)

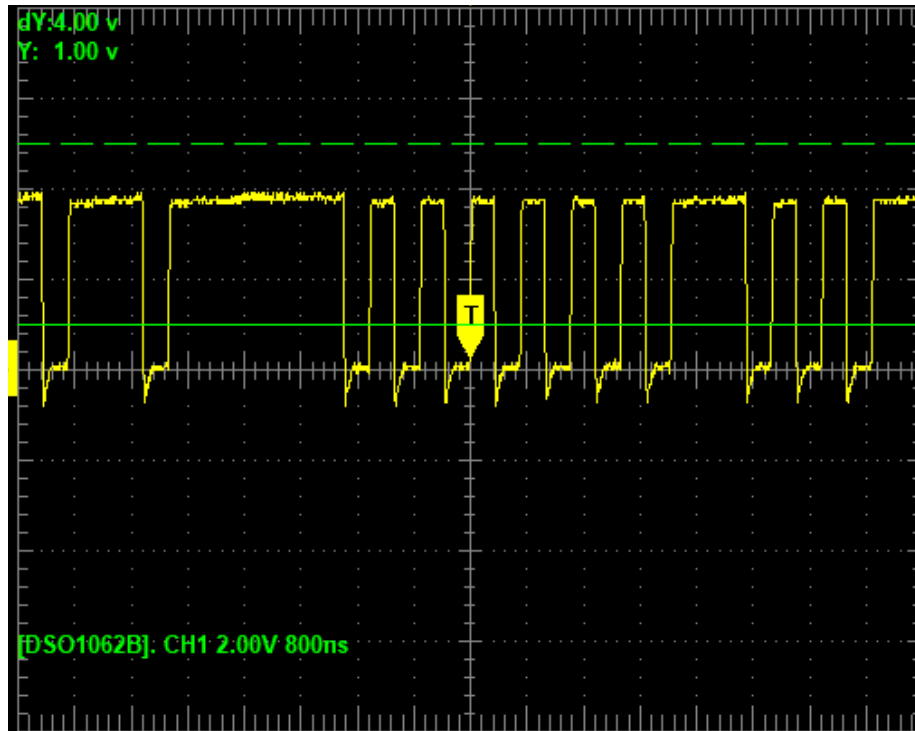

- If there is no signal, check the signal on pins 12 & 13 of IC202. If the signal on pins 12 & 13 is correct, replace IC202.

### 5.2.10 Pin 12 (Gate 4 input - A11)

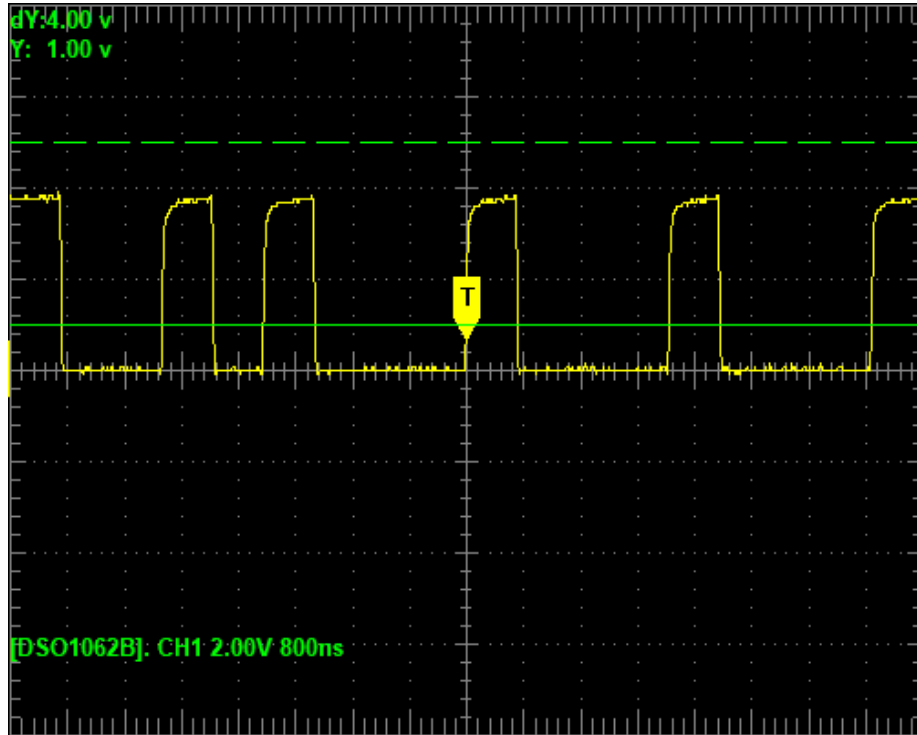

- If there is no signal, check the operation of IC206 and IC201

### 5.2.11 Pin 13 (Gate 4 input - Enable)

See IC206 Pin 34 (Enable)

### 5.2.12 Pin 14 (VCC)

Power supply +5V DC.

### 5.3 IC203 - 74LS32

Description: Quadruple gate OR

#### 5.3.1 Pin 1 (Gate 1 input - $\overline{\text{Enable}}$ )

See IC202 Pin 3 (Gate 1 output -  $\overline{\text{Enable}}$ ).

#### 5.3.2 Pin 2 (Gate 1 input - A15)

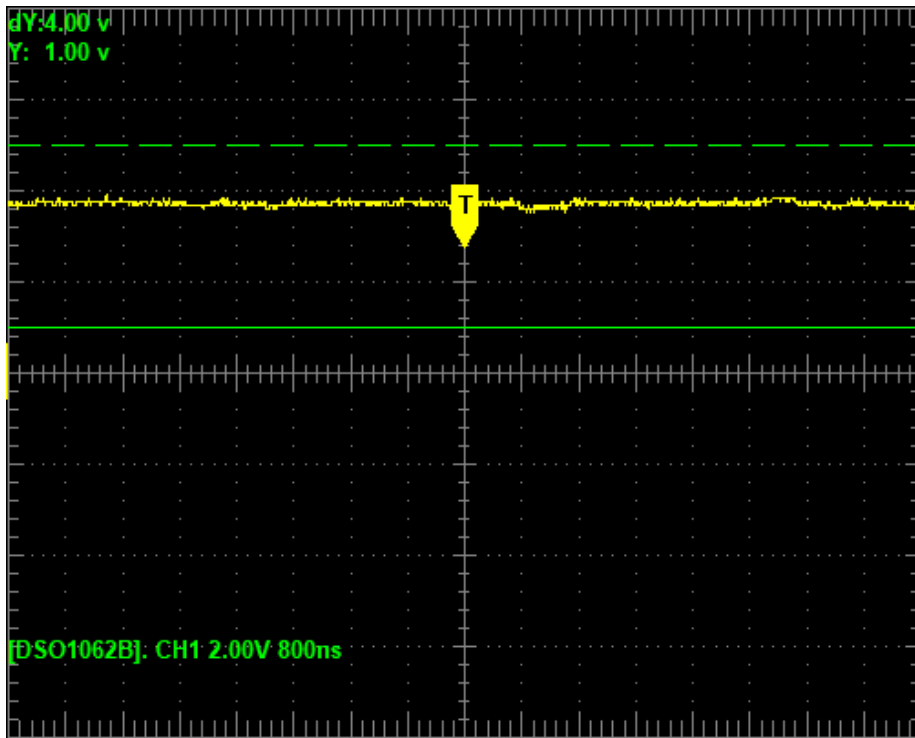

- If there is no signal, check the operation of IC206 and IC201.

### 5.3.3 Pin 3 (Gate 1 output - $\overline{\text{CARTS}}$ )

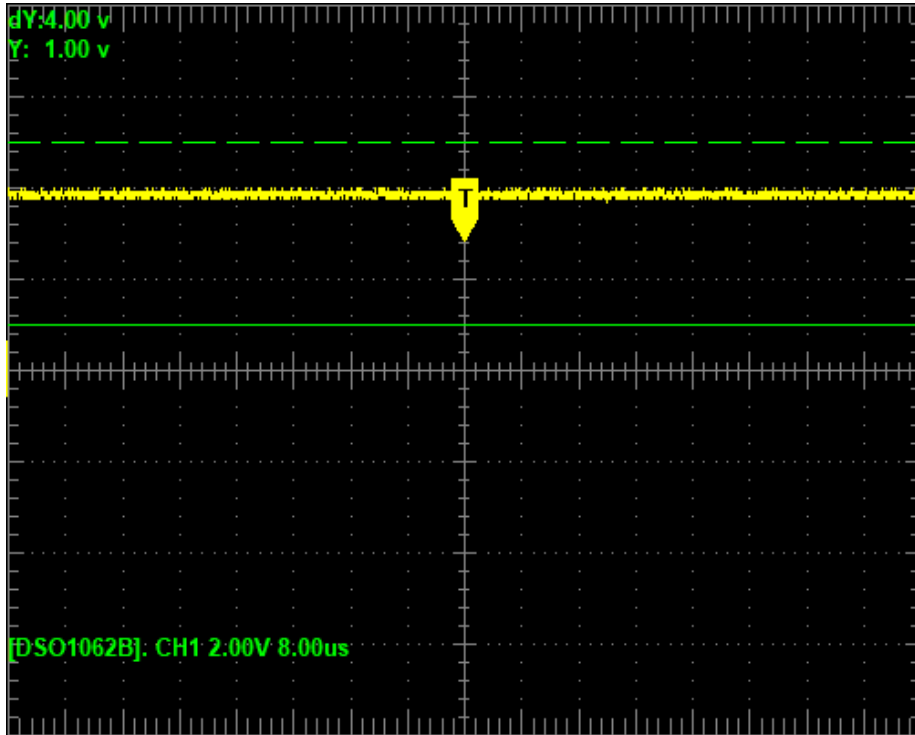

- If there is no signal, check the signal on pins 1 & 2 of IC203. If the signal on pins 1 & 2 is correct, replace IC203.

### 5.3.4 Pin 4 (Gate 2 input - $\overline{\text{RW}}$ )

See IC206 Pin 32 ( $\overline{\text{RW}}$ ).

### 5.3.5 Pin 5 (Gate 2 input - $\overline{\text{RAMS}}$ )

See IC203 Pin 8 (Gate 3 sorite -  $\overline{\text{RAMS}}$ ).

### 5.3.6 Pin 6 (Gate 2 output - RAM\_R $\bar{W}$ )

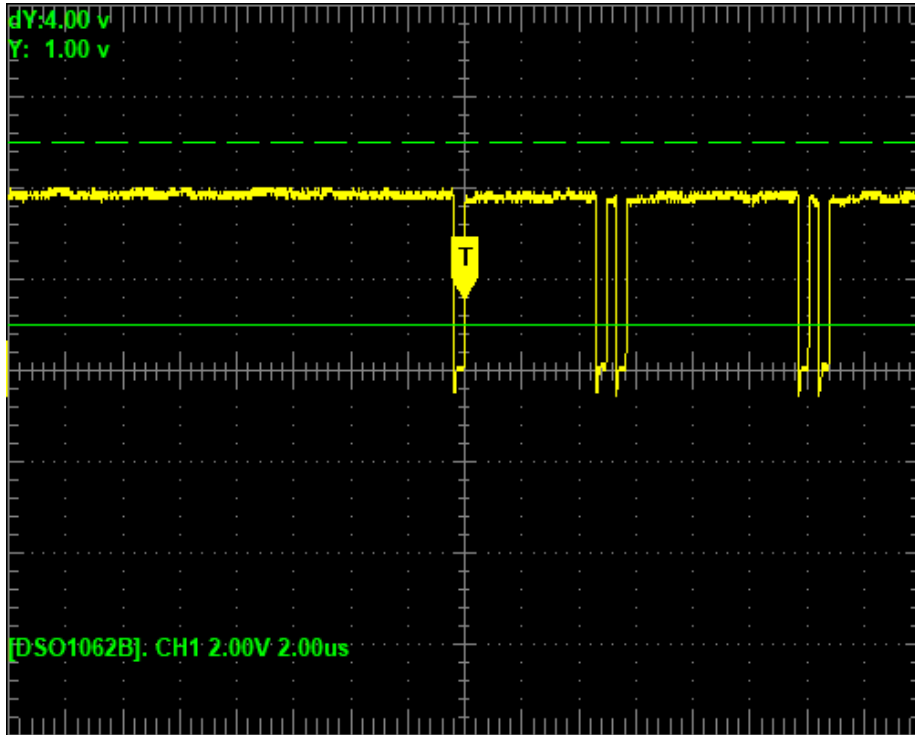

- If there is no signal, check the signal on pins 4 & 5 of IC203. If the signal on pins 4 & 5 is correct, replace IC203.

### 5.3.7 Pin 7 (GND)

Logic ground, 0V.

### 5.3.8 Pin 8 (Gate 3 sorite - $\overline{\text{RAMS}}$ )

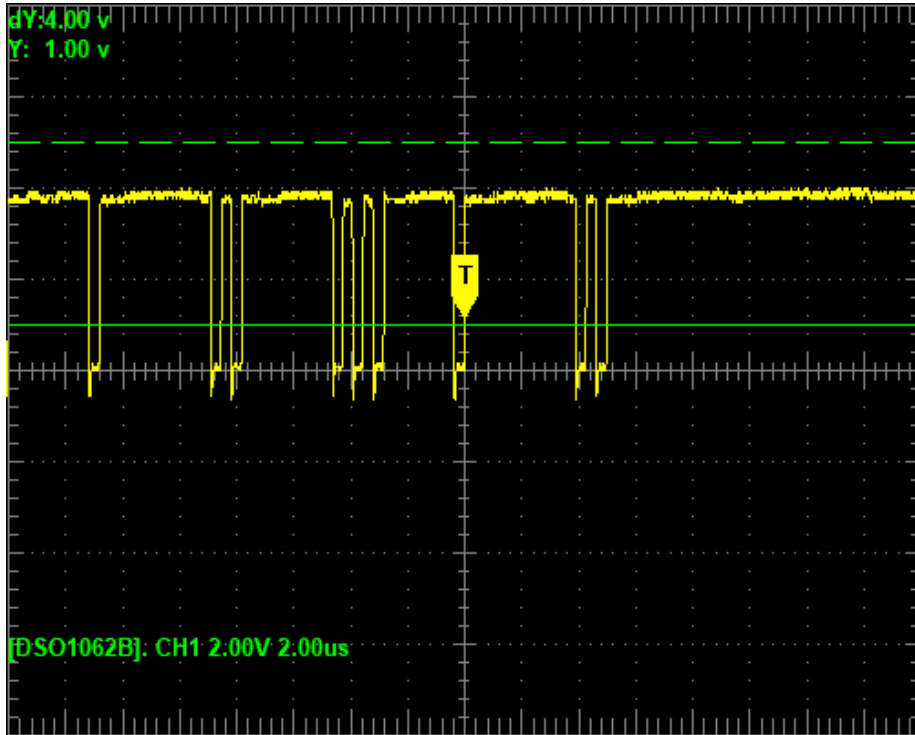

- If there is no signal, check the signal on pins 9 & 10 of IC203. If the signal on pins 9 & 10 is correct, replace IC203.

### 5.3.9 Pin 9 (Gate 3 input)

See IC202 Pin 11 (Gate 4 output)

### 5.3.10 Pin 10 (Gate 3 input - $\overline{\text{IOS}}$ )

See IC203 Pin 11 (Gate 4 output -  $\overline{\text{IOS}}$ ).



### 5.3.11 Pin 11 (Gate 4 output - $\overline{\text{IOS}}$ )

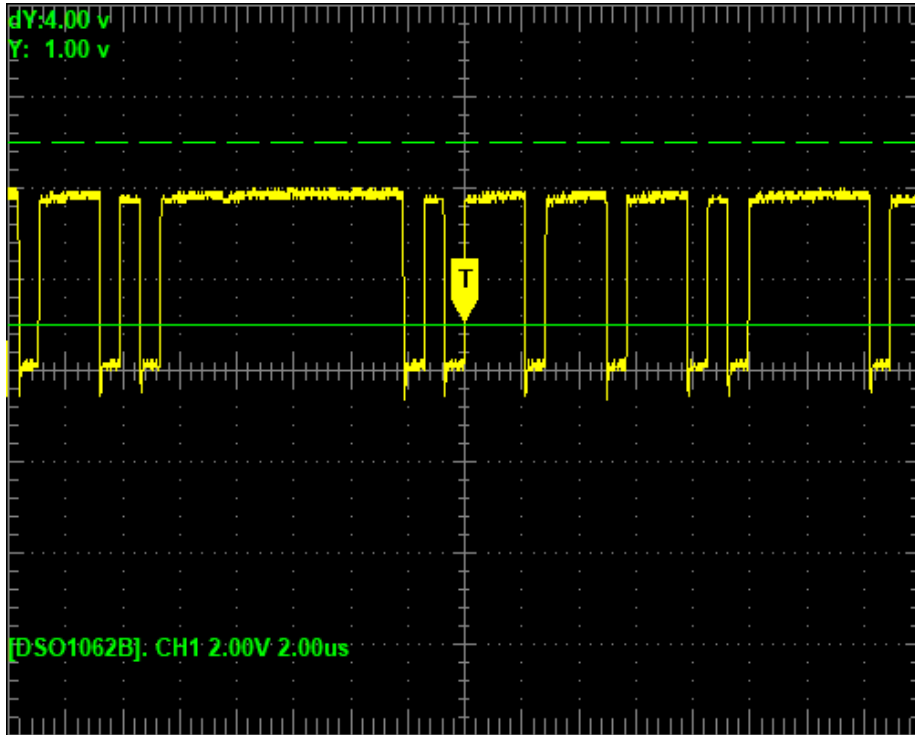

- If there is no signal, check the signal on pins 12 & 13 of IC203. If the signal on pins 12 & 13 is correct, replace IC203.

### 5.3.12 Pin 12 (Gate 4 input - $\overline{\text{ROMS}}$ )

See IC202 Pin 6 (Gate 2 output -  $\overline{\text{ROMS}}$ ).

### 5.3.13 Pin 13 (Gate 4 input - A13)

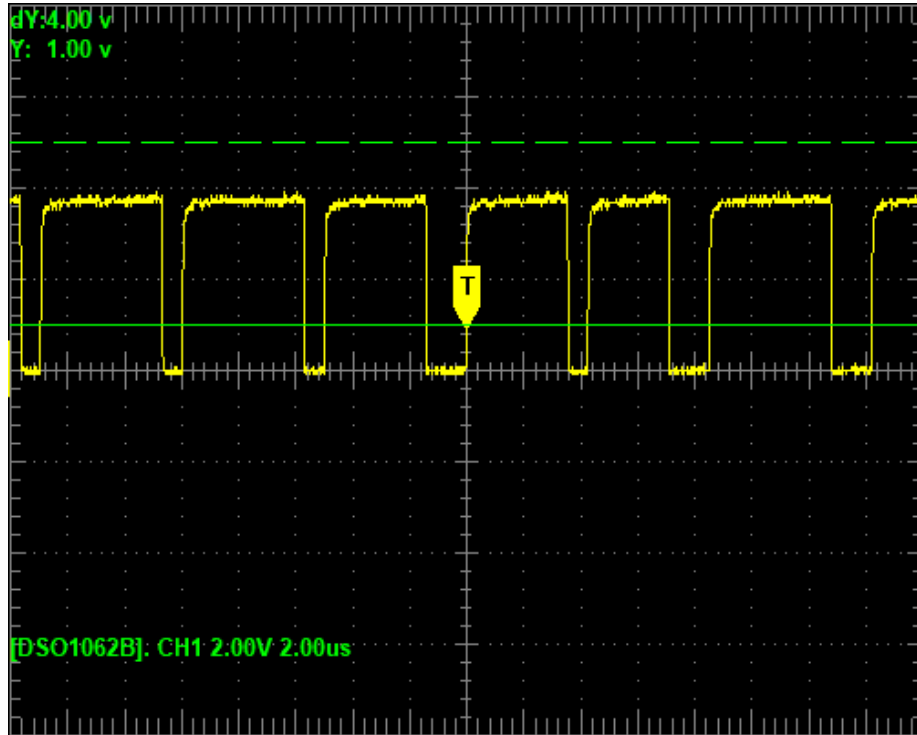

- If there is no signal, check the operation of IC206 and IC201.

### 5.3.14 Pin 14 (VCC)

Power supply +5V logic.

## **5.4 IC204, IC205 - 2114**

**Description:** RAM 1K×4bits, 300ns

### **5.4.1 Pin 1 à 7, 15, 16, 17 (A0 à A9)**

See IC206 Pins 8 à 21 (A0 à A13).

### **5.4.2 Pin 8 ( $\overline{\text{ChipSelect}}$ )**

See IC203 Pin 8 (Gate 3 sorite -  $\overline{\text{RAMS}}$ ).

### **5.4.3 Pin 9 (GND)**

Logic ground, 0V.

### **5.4.4 Pin 10 ( $\overline{\text{WriteEnable}}$ )**

See IC203 Pin 6 (Gate 2 output -  $\overline{\text{RAM\_RW}}$ ).

### **5.4.5 Pin 11 à 14 (DA à DD)**

See IC206 Pins 24 à 31 (D0 à D7).

### **5.4.6 Pin 18 (VCC)**

Power supply +5V logic.

## 5.5 IC206 - 68A09

**Description:** 8-bit processor with a frequency of 1.5 MHz

### 5.5.1 Pin 1 (GND)

Logic ground, 0V.

### 5.5.2 Pin 2 ( $\overline{\text{NMI}}$ )

This pin should be at +5V, except when using specific game cartridges.

### 5.5.3 Pin 3 ( $\overline{\text{IRQ}}$ )

This pin should be at +5V, except when using specific game cartridges.

### 5.5.4 Pin 4 ( $\overline{\text{FIRQ}}$ )

This pin should be at +5V, except when button 4 of the right joystick is pressed.

### 5.5.5 Pin 7 (VCC)

Power supply +5V logic.

### 5.5.6 Pins 8 à 21 (A0 à A13)

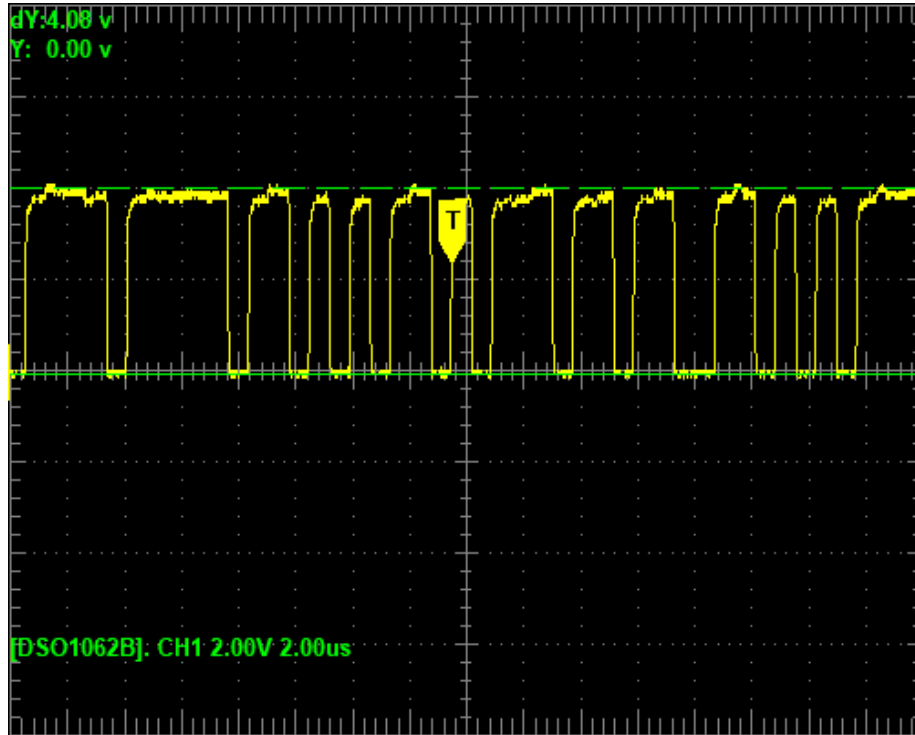

- A lack of signal on these pins indicates a problem with the processor (IC206). Start by checking pin 34 (Enable) of IC206, then check the quartz signal (Y201). If the signal is intermittent, see the paragraph on IC201 - 2363.

### 5.5.7 Pins 22 et 23 (A14 et A15)

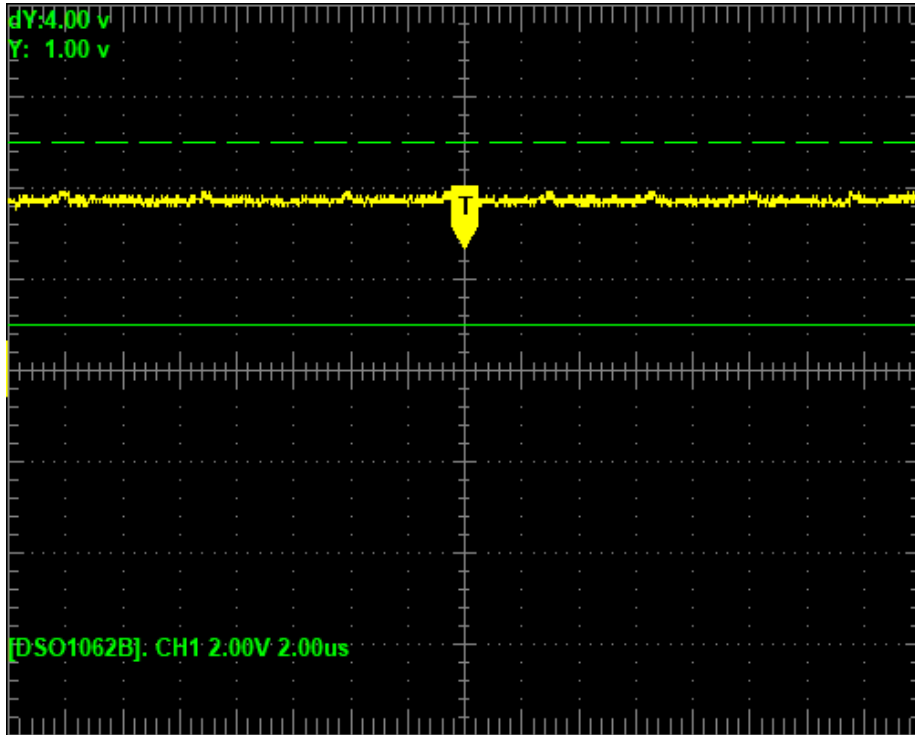

- These pins should always be at a voltage level of 4V, except when using a game cartridge. If not, check XTAL201, C210 and C222, and replace IC206 if necessary.

### 5.5.8 Pins 24 à 31 (D0 à D7)

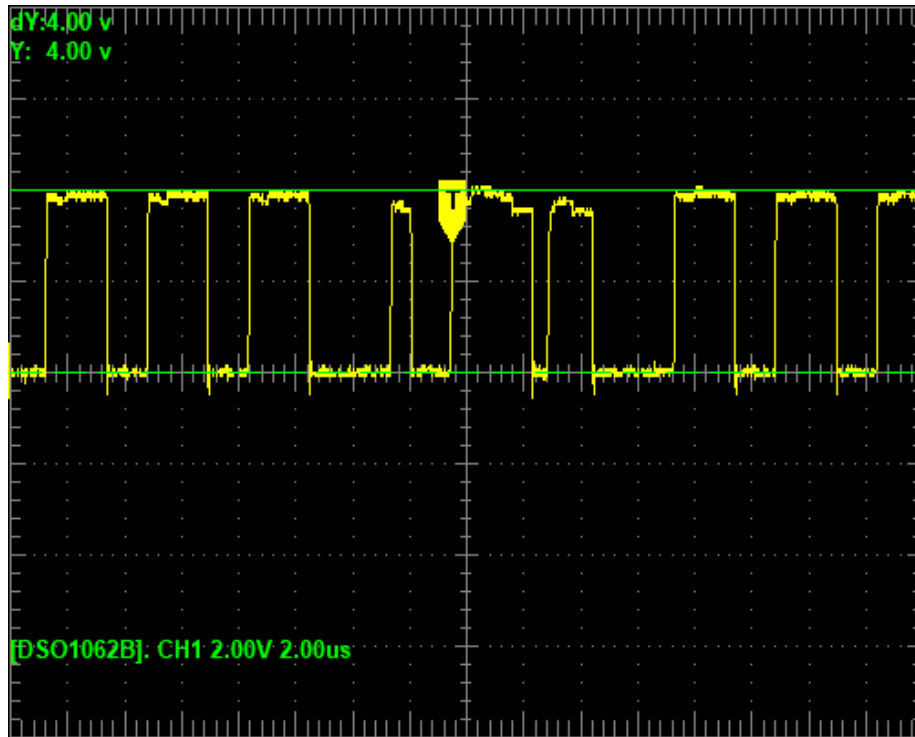

- A lack of signal on these pins indicates a problem with the processor (IC206).

### 5.5.9 Pin 32 ( $\overline{RW}$ )

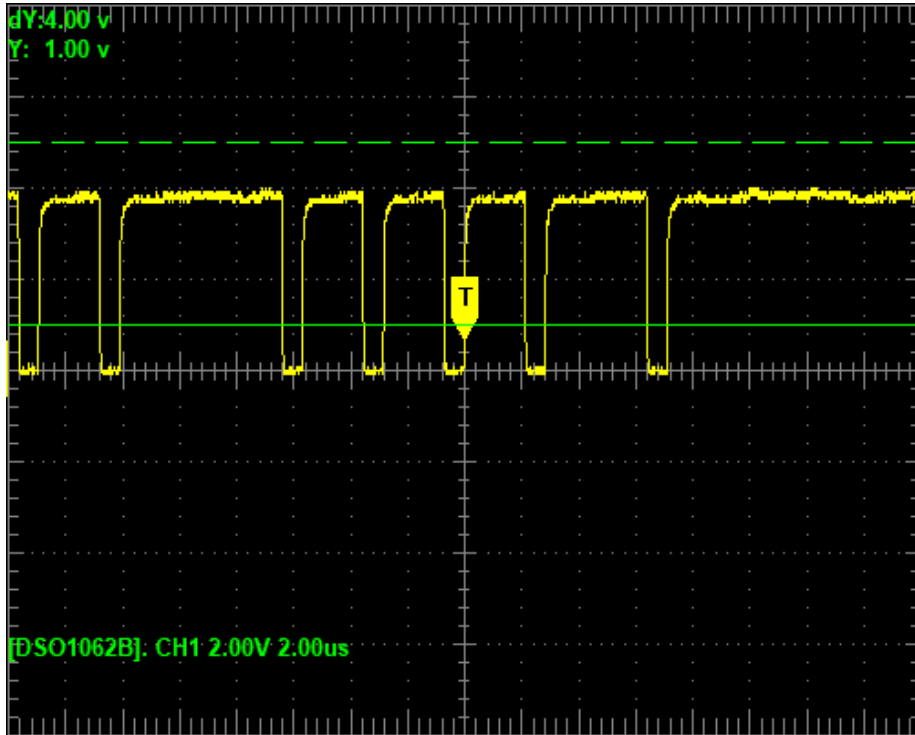

- An absence of signal on this pin indicates a problem with the processor (IC206) or with the ROM (IC201).

### 5.5.10 Pin 33 ( $\overline{DMA}$ )

This pin is connected to the +5V logic.



### 5.5.11 Pin 34 (Enable)

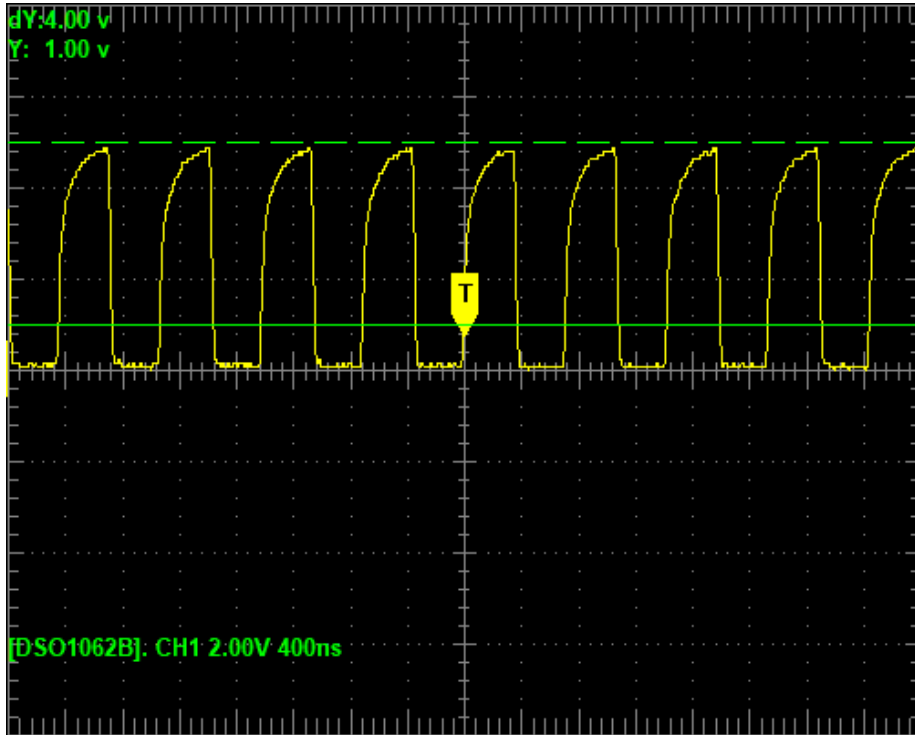

- No signal on this pin indicates a problem with the processor. No signal on this pin indicates a problem with the processor. Check R216, XTAL201, and replace the IC206 processor if necessary.

### 5.5.12 Pin 35 (Q)

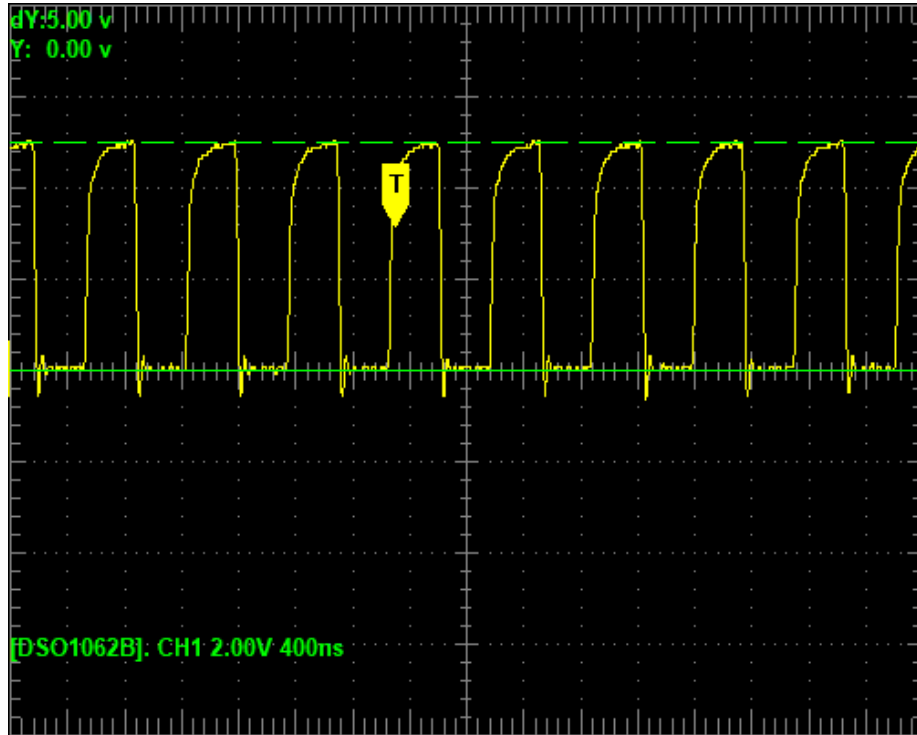

### 5.5.13 Pin 36 (MReady)

This pin is connected to the +5V logic.

### 5.5.14 Pin 37 ( $\overline{\text{Reset}}$ )

Resets IC206, IC207 and IC208. Active on a low level.

- This pin should be at +5V unless you press the Reset button. If not, replace C228, C224, C229 and D201.

### 5.5.15 Pin 38 (ExTal)

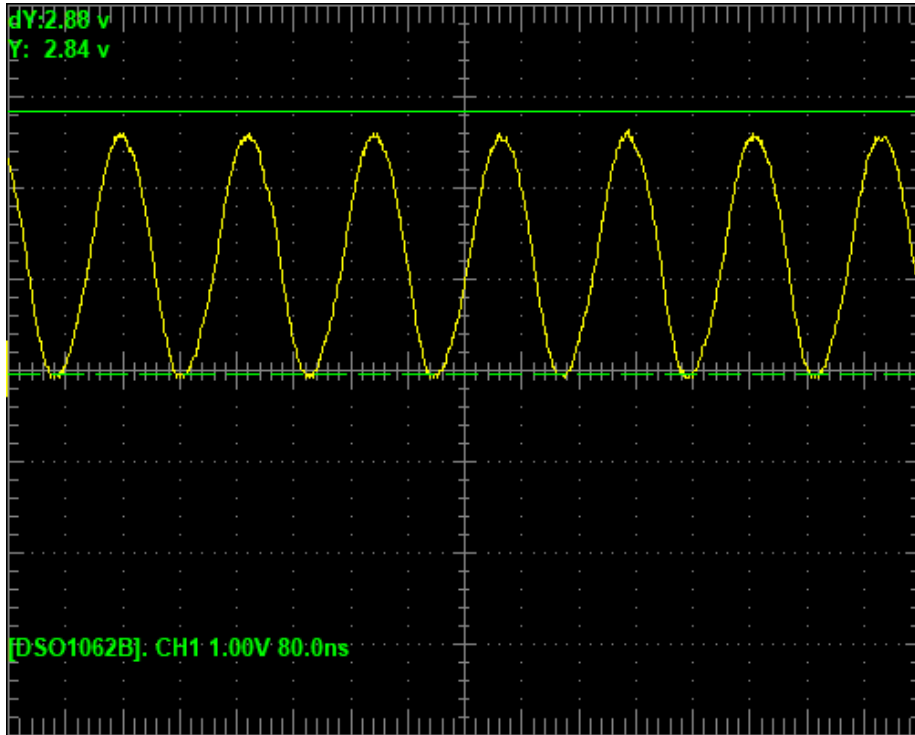

- As quartz is a sensitive component, this measurement requires your oscilloscope probe to be in 10X mode.
- If there is no signal, replace Y201, C210, C222. Then replace IC206 if necessary.

### 5.5.16 Pin 39 (XTal)

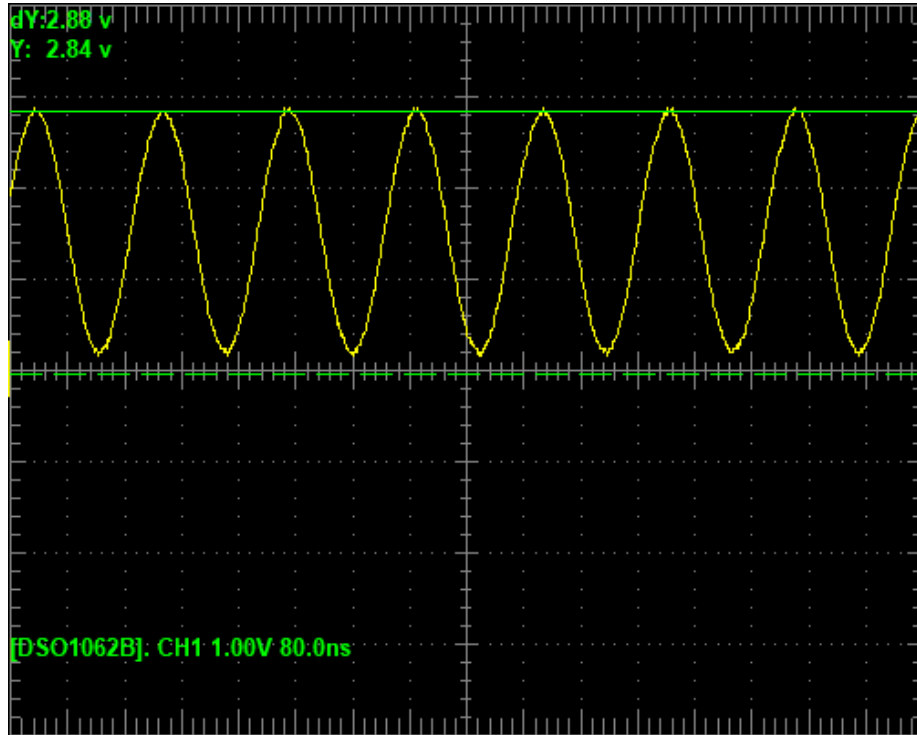

- As quartz is a sensitive component, this measurement requires your oscilloscope probe to be in 10X mode.
- If there is no signal, replace Y201, C210, C222. Then replace IC206 if necessary.

### 5.5.17 Pin 40 ( $\overline{\text{Halt}}$ )

This pin is normally never used, except with a PiTrex. Its voltage level should always be +5V.

## 5.6 IC207 - 6522

**Description:** Port extension for 68A09 processor

### 5.6.1 Pin 1 (GND)

Logic ground, 0V.

### 5.6.2 Pin 2 à 9 (PA0 à PA7)

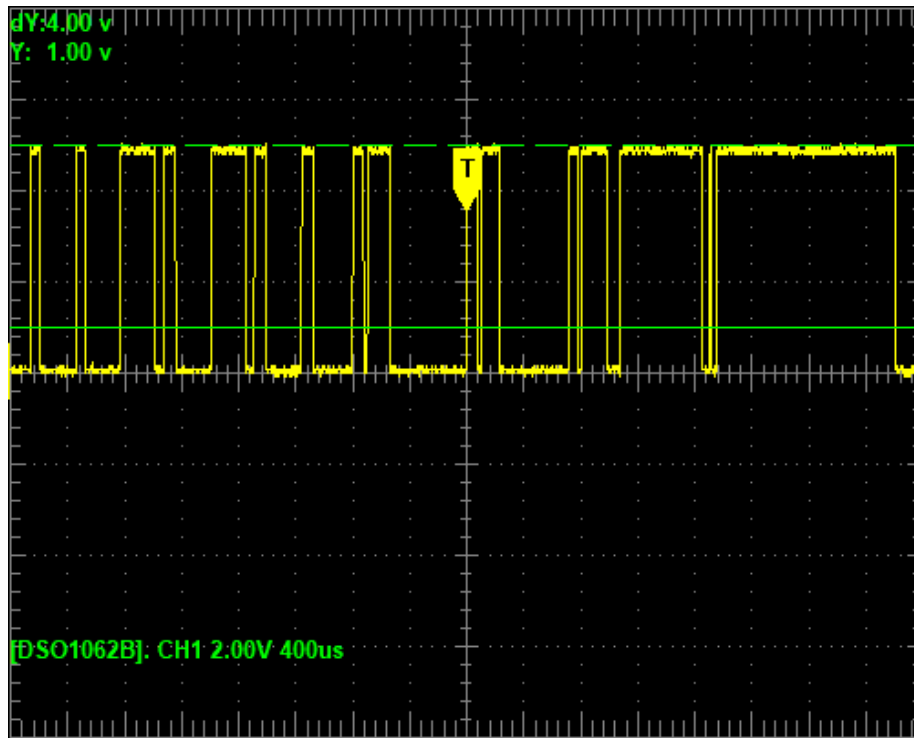

### 5.6.3 Pin 10 (PB0)

See IC302 Pin 6 (Inhibit)

### 5.6.4 Pin 11 et 12 (PB1 & PB2)

See IC302 Pin 9 et 10 (Select A et B)

5.6.5 Pin 13 (PB3)

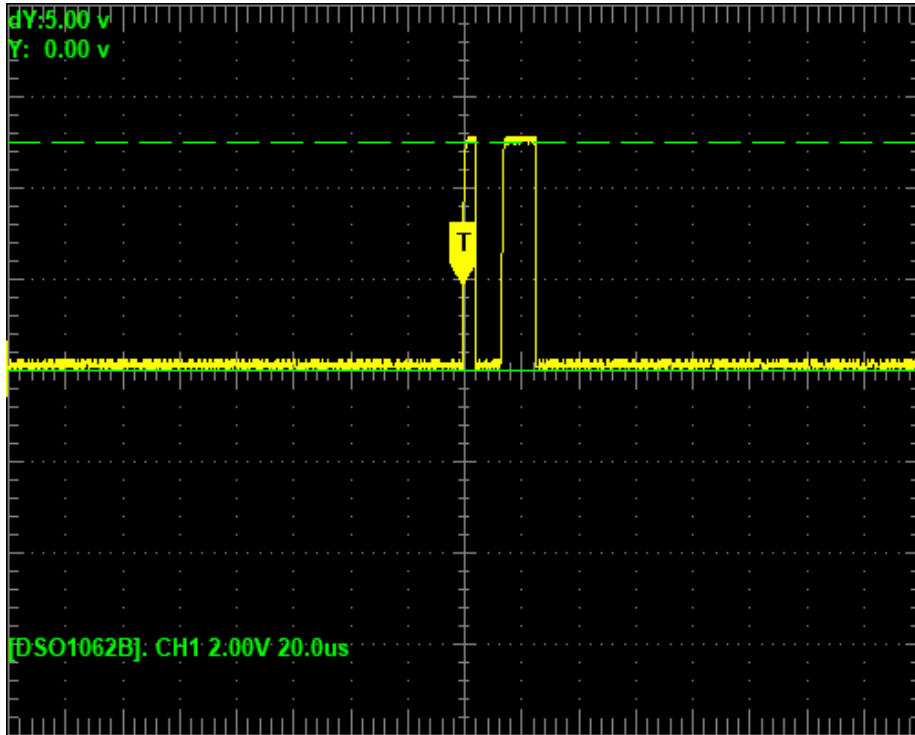

5.6.6 Pin 14 (PB4)

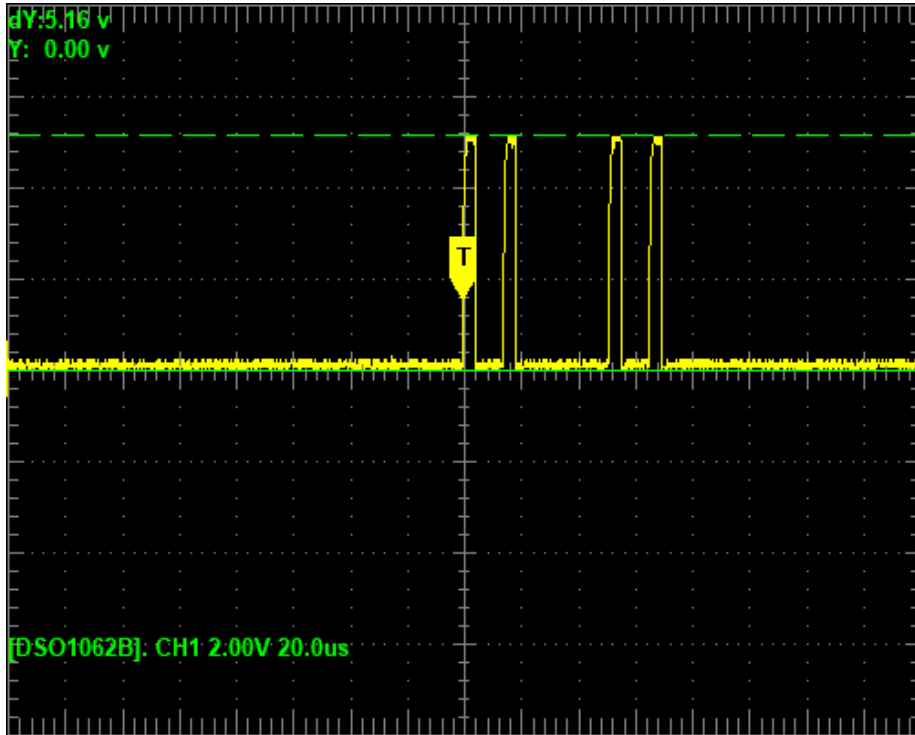

### 5.6.7 Pin 15 (PB5)

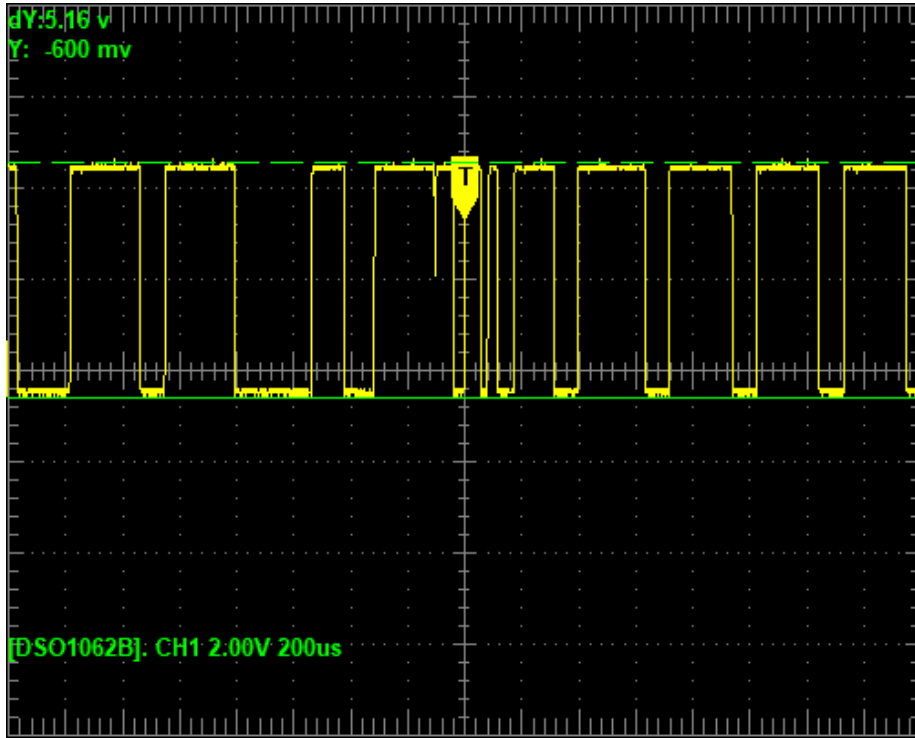

### 5.6.8 Pin 16 (PB6)

This pin should be at +5V, except when using specific game cartridges.



5.6.9 Pin 17 (PB7)

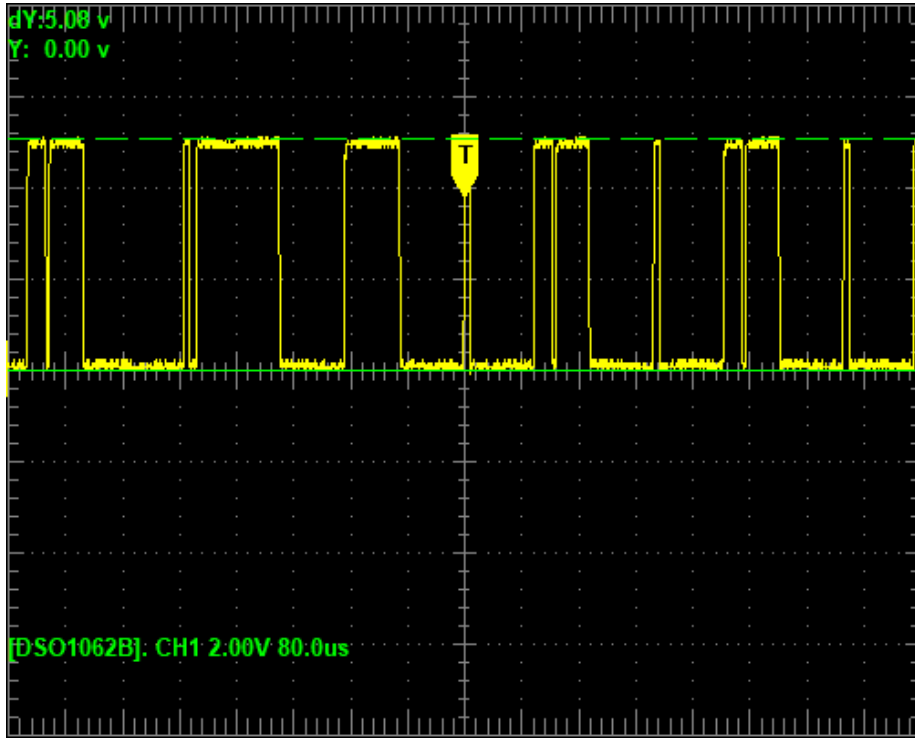

#### 5.6.10 Pin 19 (CB2)

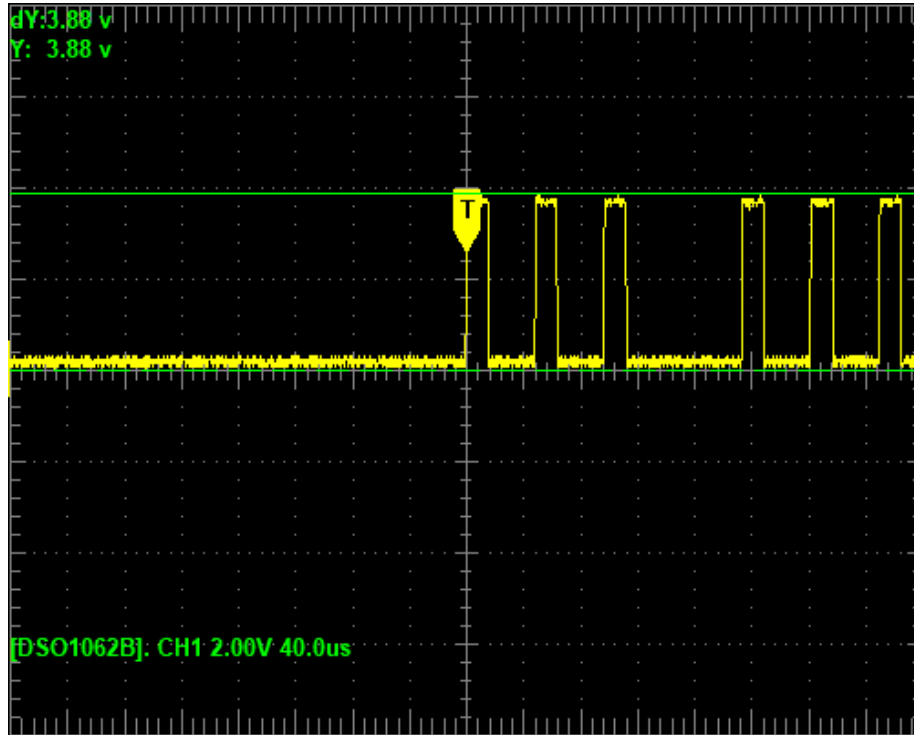

#### 5.6.11 Pin 20 (VCC)

Power supply +5V logic.

#### 5.6.12 Pin 21 ( $\overline{\text{IRQB}}$ )

See IC206 Pin 3 ( $\overline{\text{IRQ}}$ ).

#### 5.6.13 Pin 22 ( $\overline{\text{RWB}}$ )

See IC206 Pin 32 ( $\overline{\text{RW}}$ ).

#### 5.6.14 Pin 23 ( $\overline{\text{CS2B}}$ )

See IC203 Pin 11 (Gate 4 output -  $\overline{\text{IOS}}$ ).

#### 5.6.15 Pin 24 (CS1)

See IC201 Pins 8 à 21 (A0 à A13).

#### 5.6.16 Pin 25 (Enable)

See IC206 Pin 34 (Enable).

#### 5.6.17 Pin 26 à 33 (D0 à D7)

See IC206 Pins 24 à 31 (D0 à D7).

#### 5.6.18 Pin 34 ( $\overline{\text{Reset}}$ )

See IC206 Pin 37 ( $\overline{\text{Reset}}$ ).

#### 5.6.19 Pin 35 et 38 (A0 à A3)

See IC206 Pins 8 à 21 (A0 à A13).

#### 5.6.20 Pin 39 (CA2)

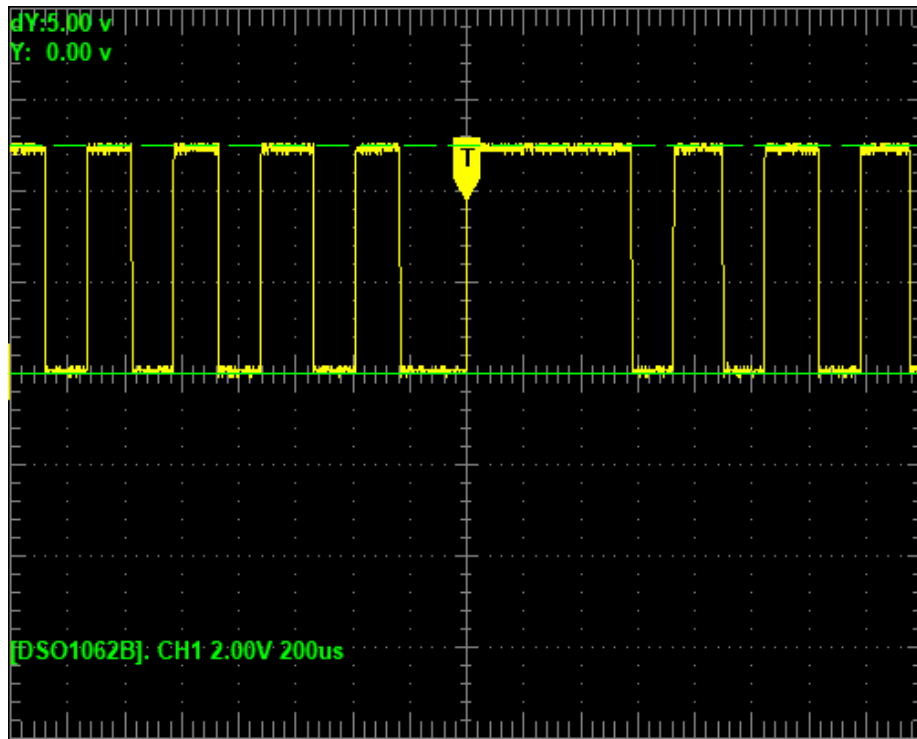

#### 5.6.21 Pin 40 (CA1)

## **5.7 IC208 - AY-3-8912**

**Description:** Sound generator

### **5.7.1 Pin 1, 4 et 5 (CHC, CHB, CHA)**

### **5.7.2 Pin 3 (VCC)**

Power supply, +5V logic.

### **5.7.3 Pin 6 (GND)**

Logic ground, 0V.

### **5.7.4 Pin 7 à 14 (IOA0 à IOA7)**

Connected to the joystick buttons. In the absence of joystick activity, these pins should return +5V.

### **5.7.5 Pin 15 (Clock)**

See IC206 Pin 34 (Enable)

### **5.7.6 Pin 16 ( $\overline{\text{Reset}}$ )**

See IC206 Pin 37 ( $\overline{\text{Reset}}$ )

### **5.7.7 Pin 17 (A8)**

Connected to +5V logic via R207.

### **5.7.8 Pin 18 (BDir)**

See IC207 Pin 14 (PB4)

### **5.7.9 Pin 19 (BC2)**

Connected to +5V logic via R207.

### **5.7.10 Pin 20 (BC1)**

See IC207 Pin 13 (PB3)

### **5.7.11 Pin 21 à 28 (DA0 à DA7)**

See IC207 Pin 2 à 9 (PA0 à PA7)

## 5.8 IC301 - MC-1408P8

**Description:** 8-bit digital-to-analog converter.

### 5.8.1 Pin 1 (Range / Not connected)

Not used.

### 5.8.2 Pin 2 (GND)

Analog ground, 0V.

### 5.8.3 Pin 3 (VEE)

-13V analog.

### 5.8.4 Pin 4 (I<sub>OUT</sub>)

It is not possible to make reliable measurements on this pin. Measure IC302 Pin 13 (Common X) to check the operation of IC301.

### 5.8.5 Pin 5 à 12 (DA0 à DA7)

See IC207 Pin 2 à 9 (PA0 à PA7)

### 5.8.6 Pin 13 (VCC)

Power supply, +5V analog.

### 5.8.7 Pin 14 (V<sub>REF+</sub>)

+5V analog via R304.

### 5.8.8 Pin 15 (V<sub>REF-</sub>)

Analog ground via R305.

### 5.8.9 Pin 16 (Compensation)

About -10V DC, via C303.

## 5.9 IC302 - 4052B

**Description:** double multiplexer/demultiplexer.

The first multiplexer takes as input (pin 13) the signal coming from the DAC IC301. And redirects these signals as needed to pins 11 (digitalized sound), 12 (vertical video signal), 14 (?) and 15 (image intensity).

The second multiplexer is used to select the potentiometer of the analog joysticks (pin 1, 2, 4 and 5) which will be read (pin 3). The analysis of these pins is therefore useless to correct an image problem of the Vectrex.

### 5.9.1 Pin 1, 2, 4 et 5 (Y channels In/Out)

Pin to read the potentiometers of the joysticks. No interest to repair the common problems of the Vectrex.

### 5.9.2 Pin 3 (Common Y)

Output pin of the joysticks potentiometers. No interest to repair the common problems of the Vectrex.

### 5.9.3 Pin 6 (Inhibit)

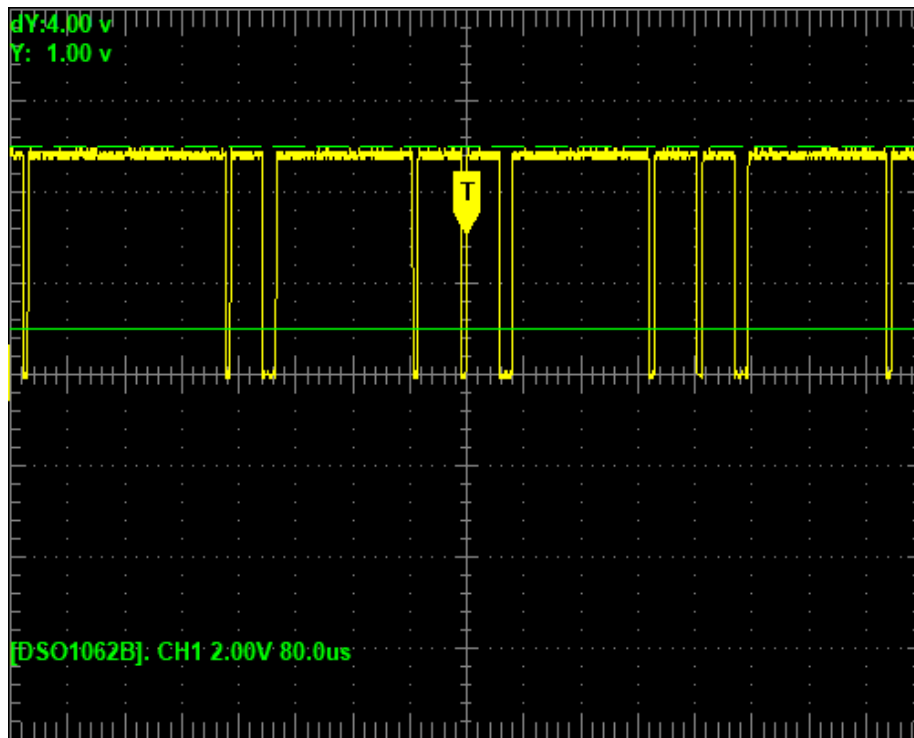

- If there is no signal, replace IC207 (PIA 6522).

#### 5.9.4 Pin 7 (VEE)

-5V analog.

#### 5.9.5 Pin 8 (VSS)

Analog ground, 0V.

#### 5.9.6 Pin 9 et 10 (Select A et B)

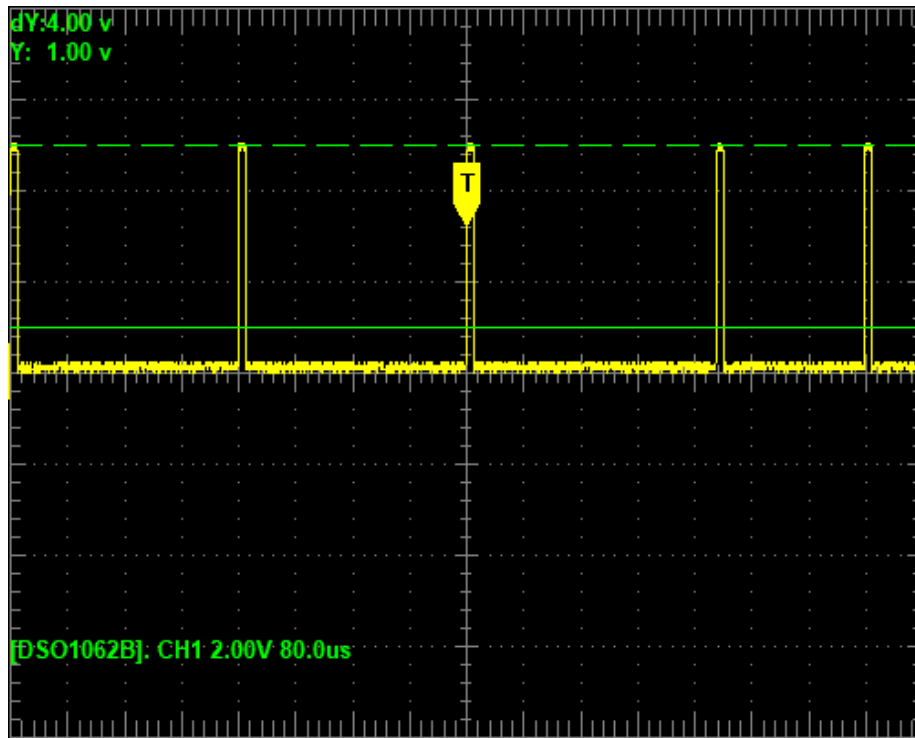

- If no signal, replace IC207 (PIA 6522)

#### 5.9.7 Pin 11 (X Channel 3)

Output for digitized sounds. There is no digitalized sound in the Vectrex startup screen or in the Minestorm game. Except in games with digitized sound, the voltage on this pin should be 0V.

### 5.9.8 Pin 12 (X Channel 0)

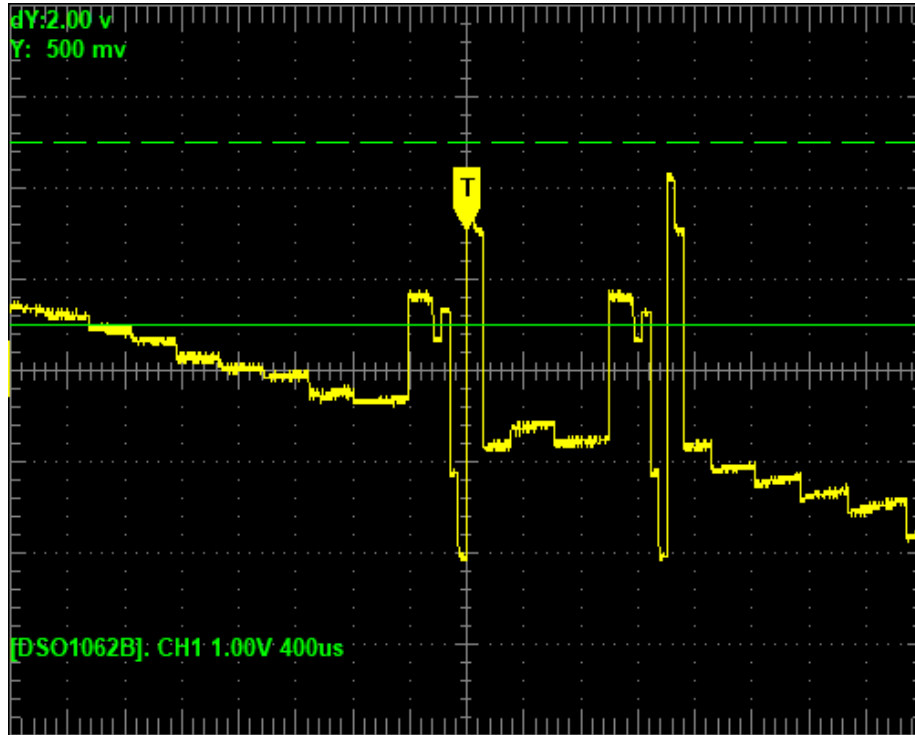

- If there is no signal, check the signals on pins 6, 9, 10 and 13. If all these signals are correct, then replace the CD4052B and/or the C304 capacitor.
- If the signal is distorted, check the signals on pins 6, 9, 10 and 13. Check the presence of the -5V voltage on the J204 power supply cable. If all these signals are correct, then replace the CD4052B.



### 5.9.9 Pin 13 (Common X)

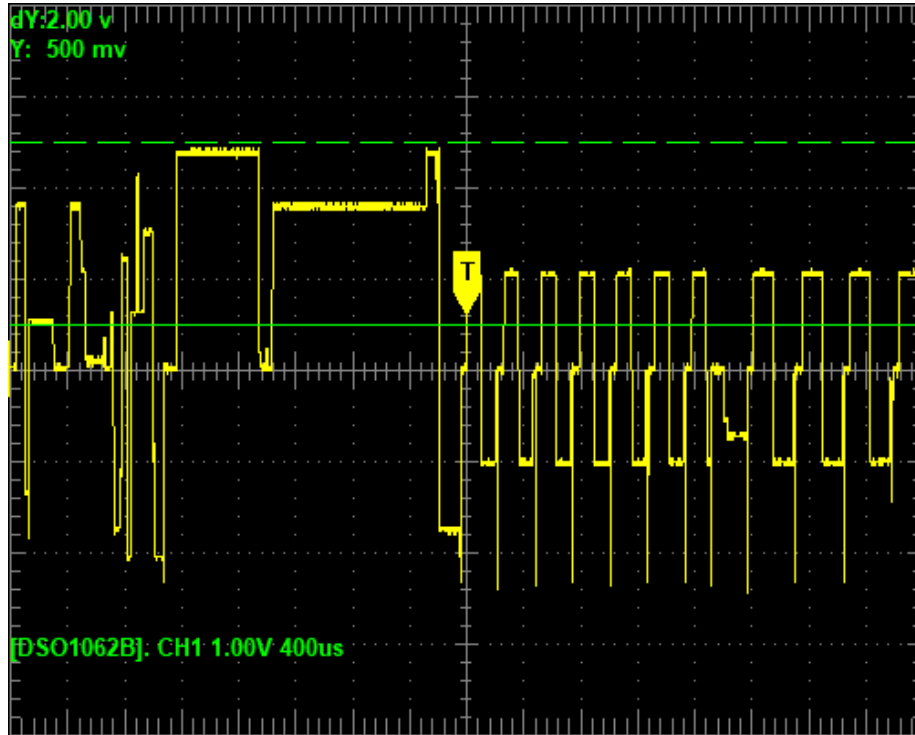

- If there is no signal, check the signals on pins 5 to 12 of IC301 (MC-1408P8), check the presence of the -13V voltage on the power supply cable J204. If all these signals are correct, replace IC301 and IC304.

### 5.9.10 Pin 14 (X Channel 1)

Output for direct and simultaneous control of X and Y signal amplification. This output allows to zoom or change the precision of the signal. This output is not used in the Vectrex startup screen or in the Minestorm game. The test on this pin is 0V.

### 5.9.11 Pin 15 (X Channel 2)

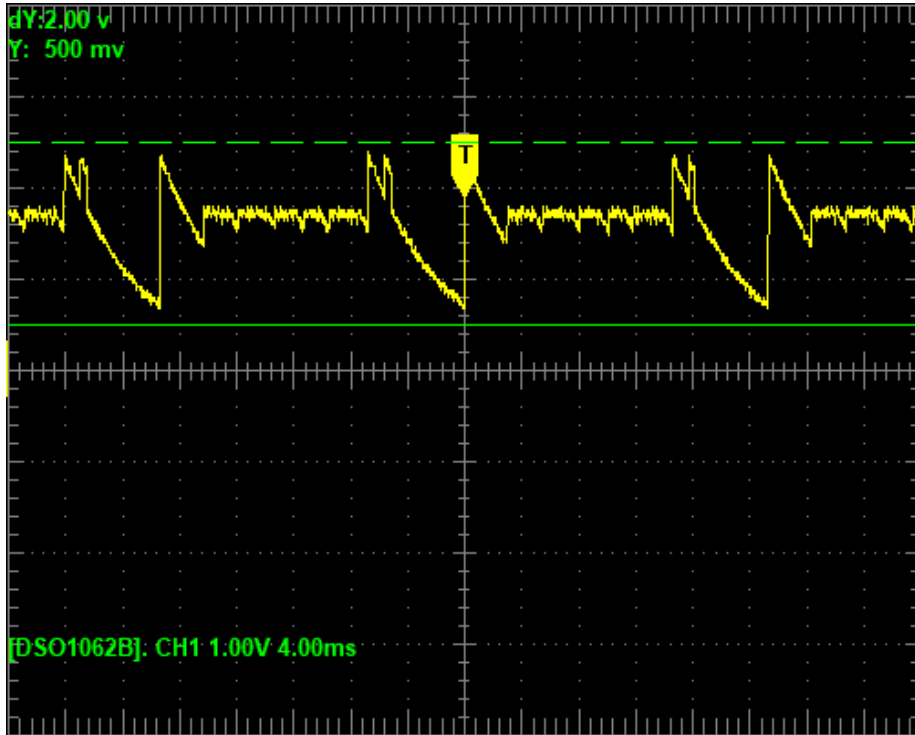

- If there is no signal, check the signals on pins 6, 9, 10 and 13. If all these signals are correct, then replace the CD4052B and/or the C306 capacitor.
- In case of distorted signal, check the signals on pins 6, 9, 10 and 13. Check the presence of the -5V voltage on the J204 power supply cable. If all these signals are correct, then replace the CD4052B.

### 5.9.12 Pin 16 (VDD)

Power supply, +5V analog.

## 5.10 IC303 - LF347

### 5.10.1 Pin 1 (Output)

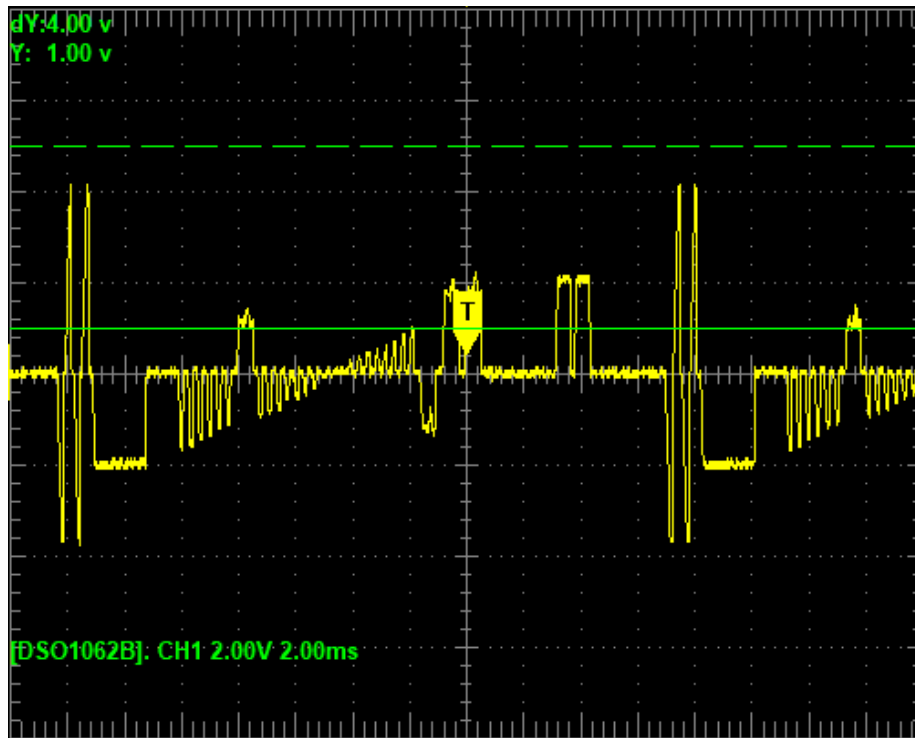

- If there is no signal, check pins 2 and 3 of IC303. If all these signals are correct, then replace C312, then IC303.
- If the signal is distorted, replace C312, IC303 and IC305.

### 5.10.2 Pin 2 (Input)

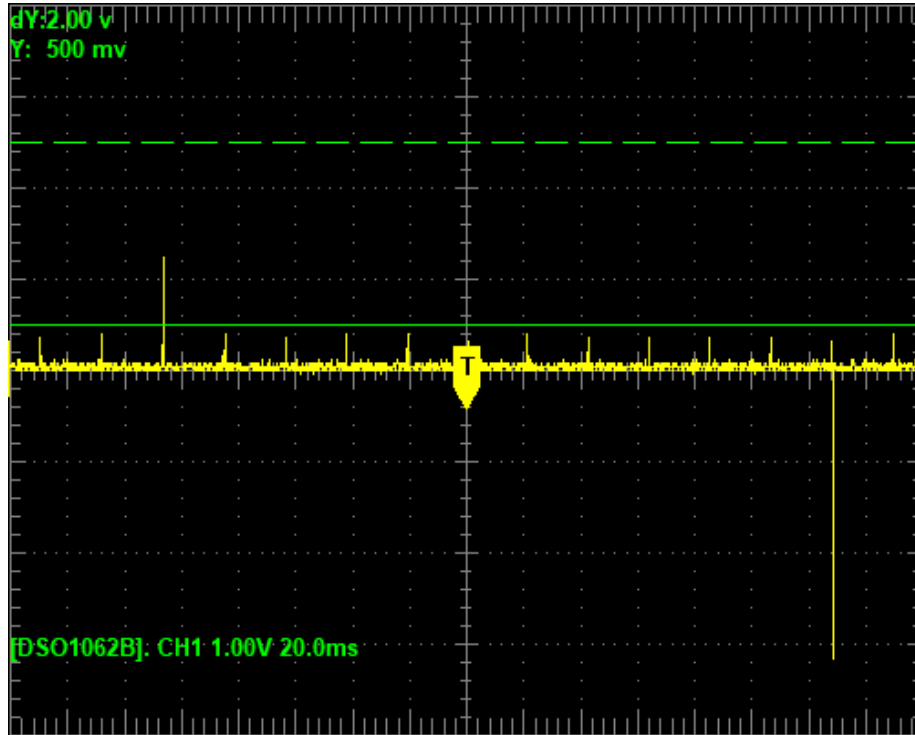

- If there is no signal, check pins 1 and 3 of IC305. Replace IC305 if necessary.

### 5.10.3 Pin 3 (Input)

See IC302 Pin 14 (X Channel 1)

### 5.10.4 Pin 4

Power supply, +5V analog.

### 5.10.5 Pin 5 (Input)

See IC302 Pin 12 (X Channel 0)

### 5.10.6 Pin 6 (Input)

See IC303 Pin 7 (Output)

### 5.10.7 Pin 7 (Output)

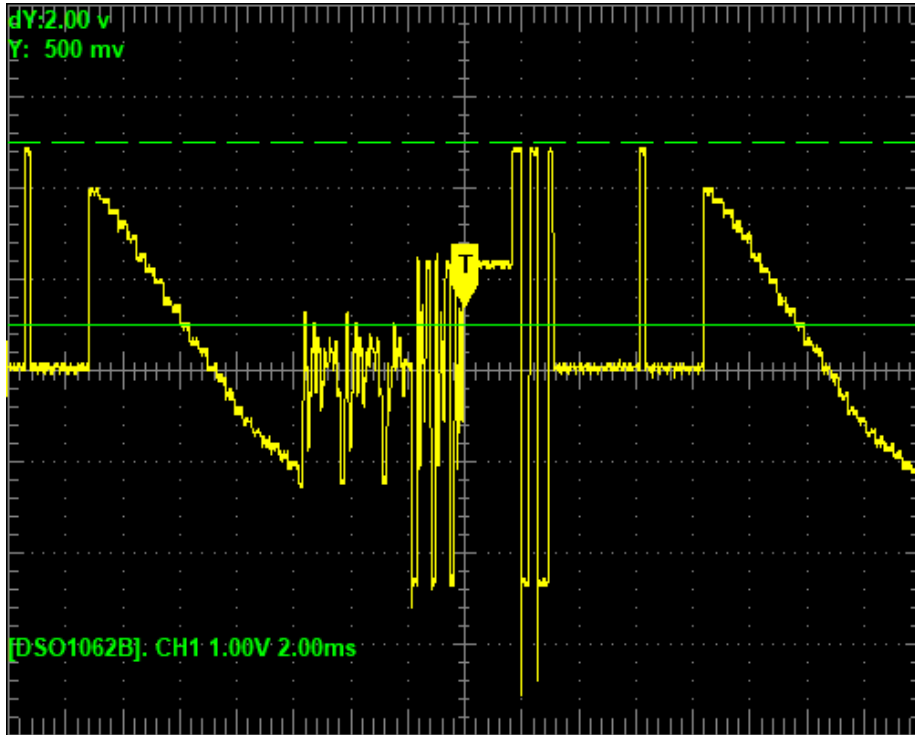

- If there is no signal or a distorted signal, check pin 12 of IC302. Replace C304, then IC303, then IC305 if necessary.

### 5.10.8 Pin 8 (Output)

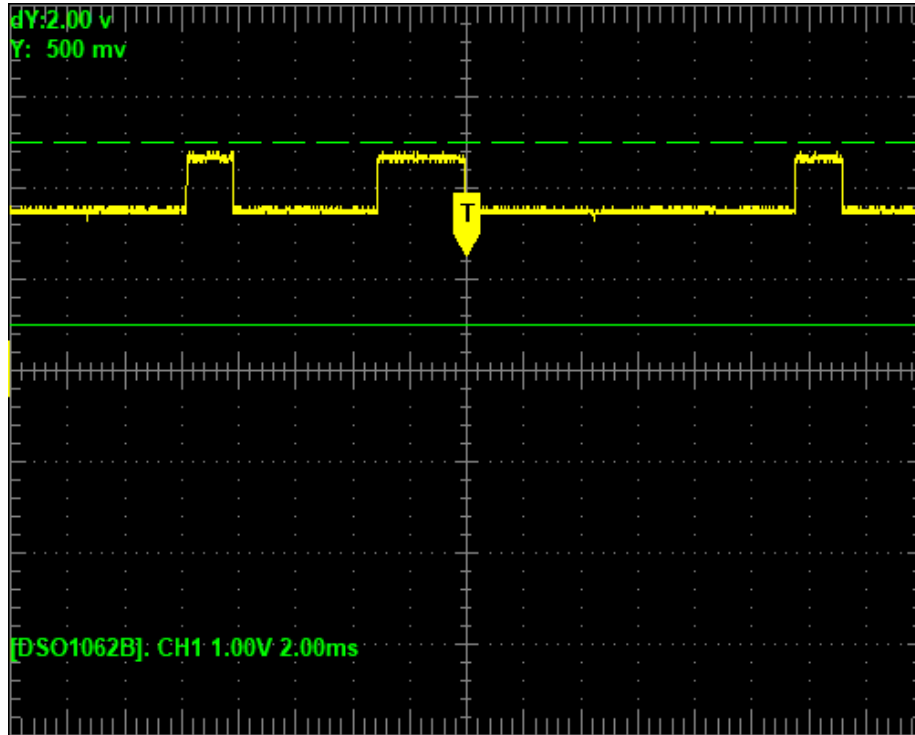

- If there is no signal, check pin 15 of IC302. Replace C306, then IC303 if necessary.

### 5.10.9 Pin 9 (Input)

See IC303 Pin 8 (Output)

### 5.10.10 Pin 10 (Input)

See IC302 Pin 15 (X Channel 2)

### 5.10.11 Pin 11

Analog ground, 0V.

### 5.10.12 Pin 12 (Input)

See IC302 Pin 14 (X Channel 1)

### 5.10.13 Pin 13 (Input)

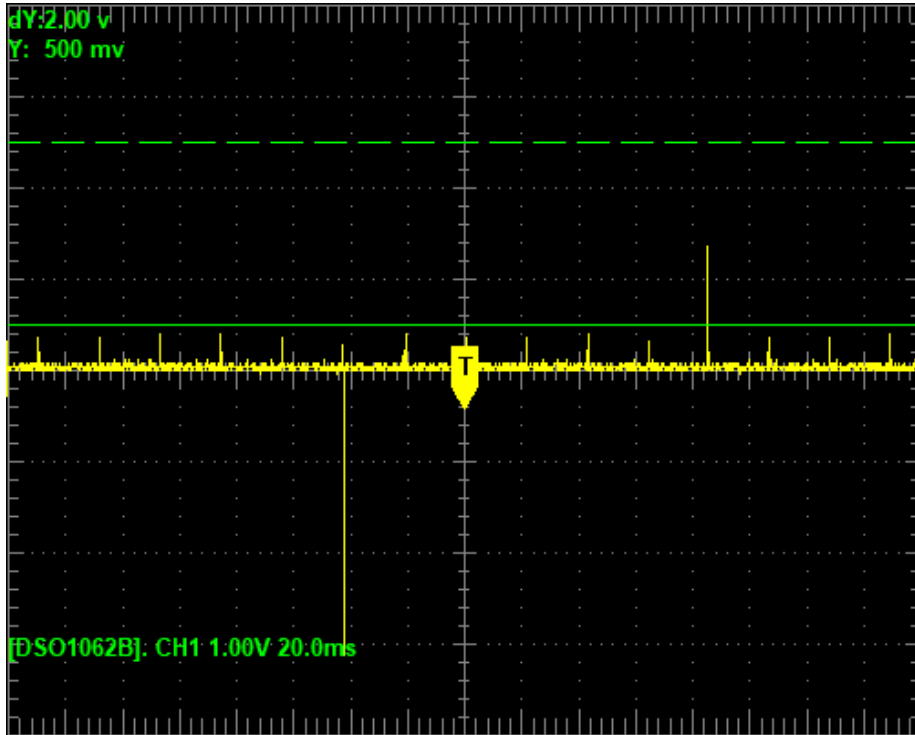

- If there is no signal or a distorted signal, check the signal on pin 9 of IC305. Replace C313, then IC303 if necessary. Also check C327 and R335.

#### 5.10.14 Pin 14 (Output)

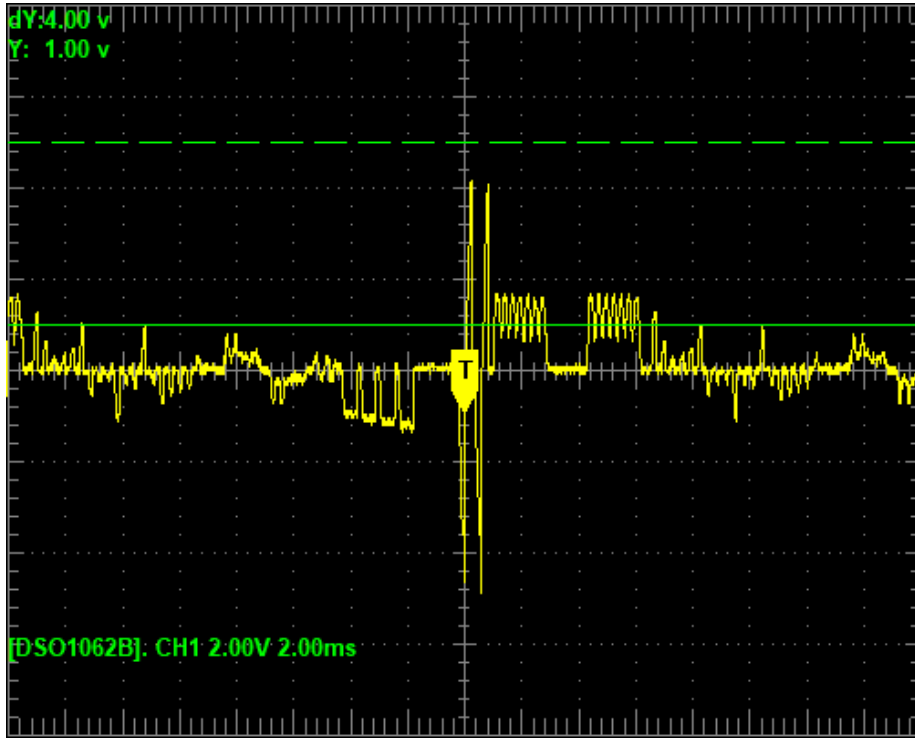

- If there is no signal or a distorted signal, check pins 12 and 13 of IC303. Replace C313, then IC303 if necessary.



## 5.11 IC304 - LF353

### 5.11.1 Pin 1 (Output)

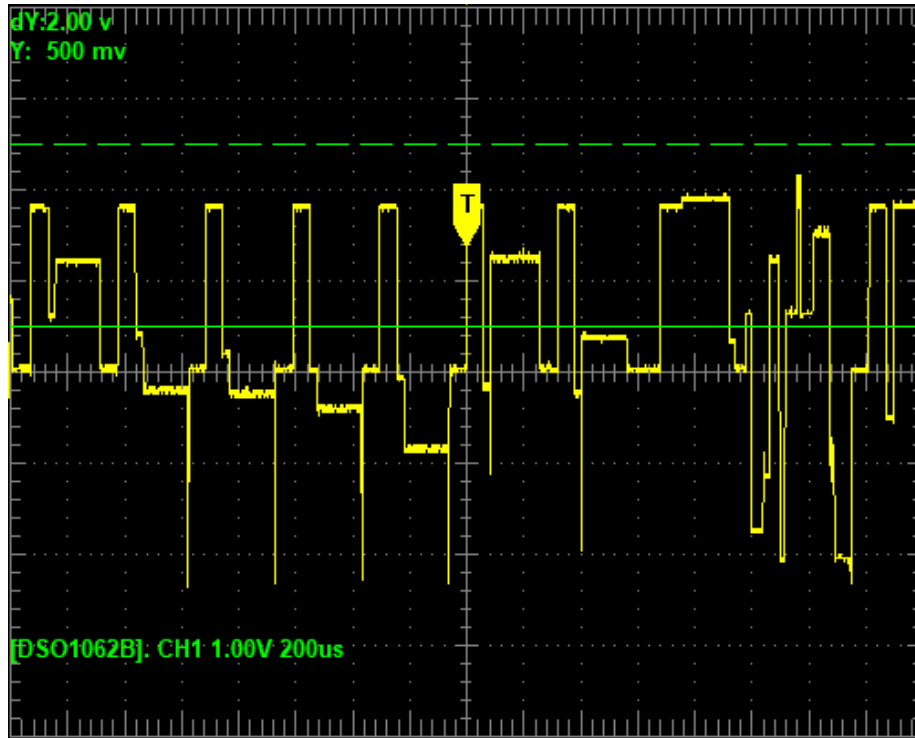

- If there is no signal, check all the signals on IC301, replace C315, then IC301 and IC304 if necessary. Check R302 if necessary.
- A malfunction of components IC302, IC304 and IC305 may also block the signal from IC304. You can remove them while you check the operation of pin 1 of IC304.

### 5.11.2 Pin 2 (Input)

See IC301 Pin 4 ( $I_{OUT}$ )

### 5.11.3 Pin 3 (Input)

Analog ground, 0V.

### 5.11.4 Pin 4

Analog ground, 0V.

#### 5.11.5 Pin 5 (Input)

See IC302 Pin 3 (Common Y)

#### 5.11.6 Pin 6 (Input)

See IC304 Pin 1 (Output)

#### 5.11.7 Pin 7 (Output)

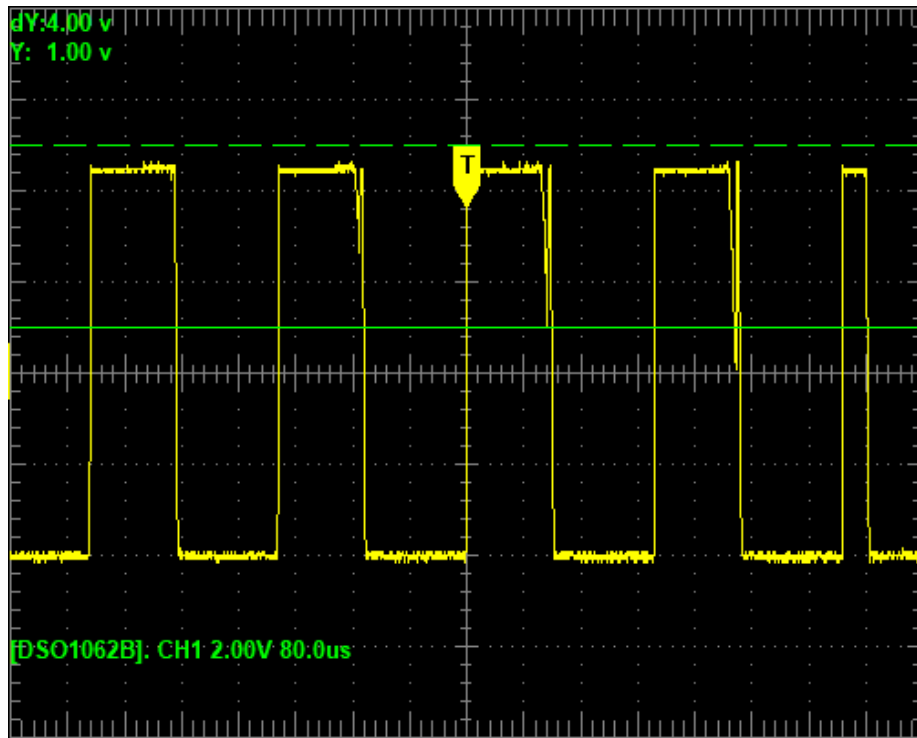

- If there is no signal or a distorted signal, check pins 5 and 6 of IC304. Replace D301 then IC304 if necessary.

#### 5.11.8 Pin 8

Power supply, +5V analog.

## 5.12 IC305 - 4066B

### 5.12.1 Pin 1 (Input)

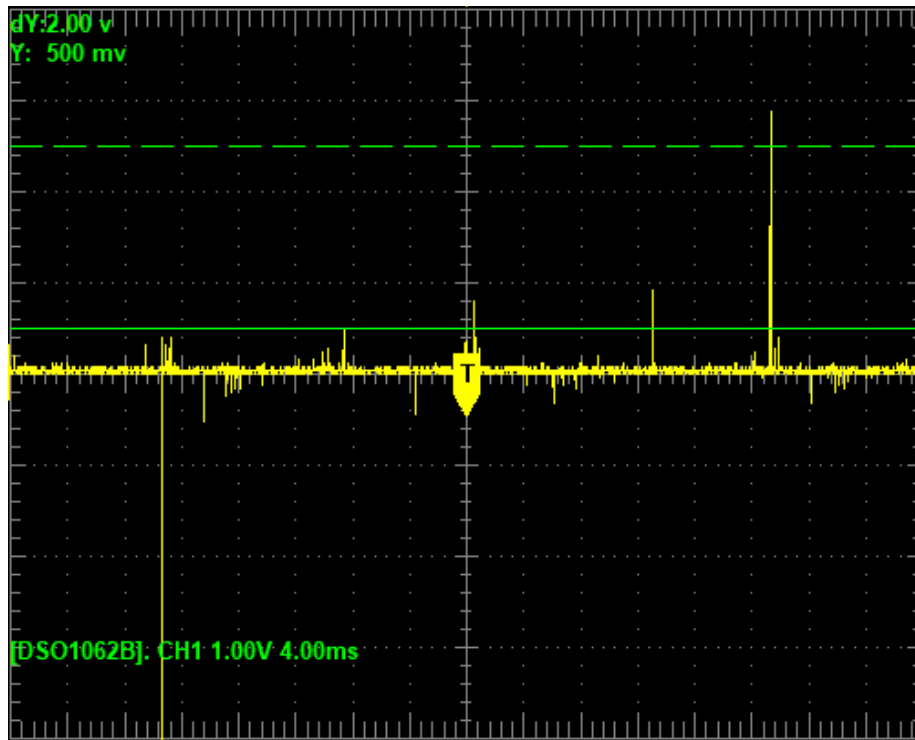

- If there is no signal or a distorted signal, check pin 13 of IC305. Check the signal on pin 2 of IC303. Replace C312, then IC305 and IC303 if necessary.

### 5.12.2 Pin 2 (Output)

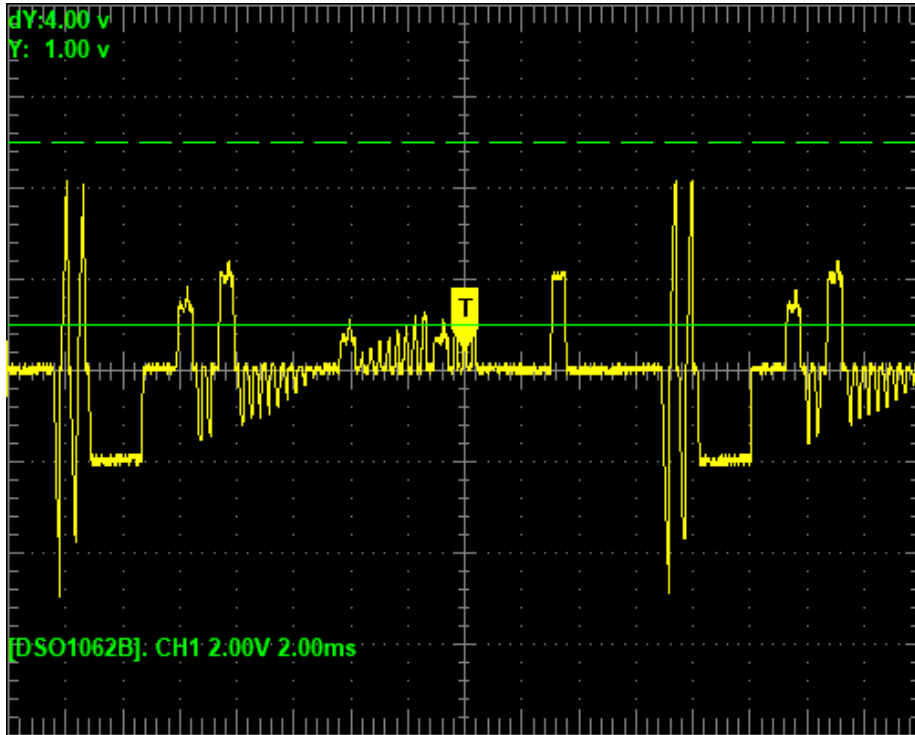

- If there is no signal or a distorted signal, check pin 1 and 13 of IC305. Check the signal on pin 1 and 2 of IC303. Replace C312, then IC305 and IC303 if necessary.

### 5.12.3 Pin 3 (Output)

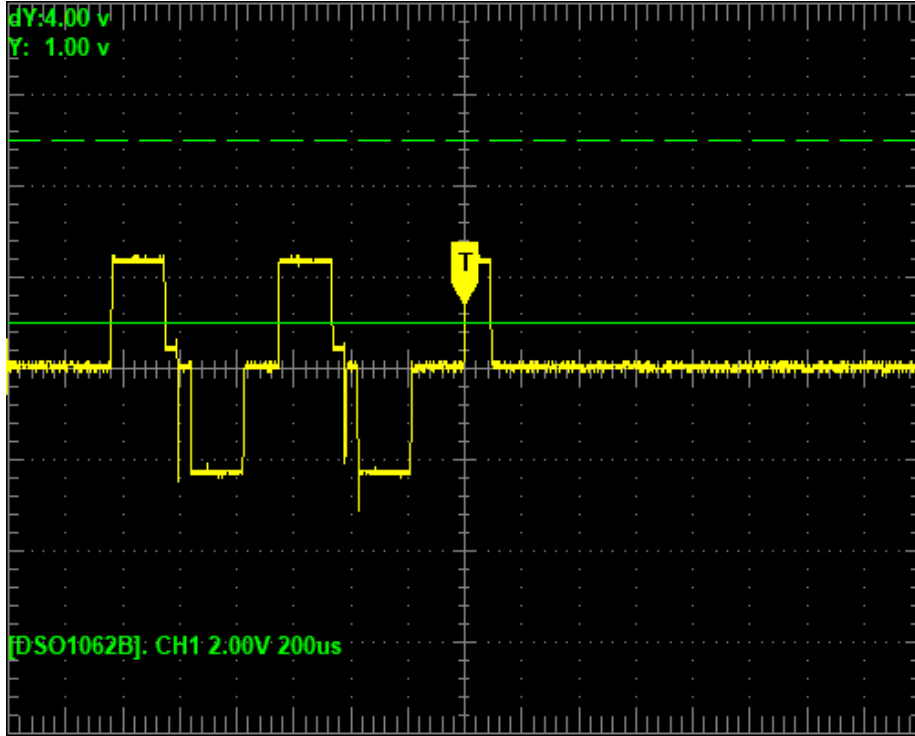

#### 5.12.4 Pin 4 (Input)

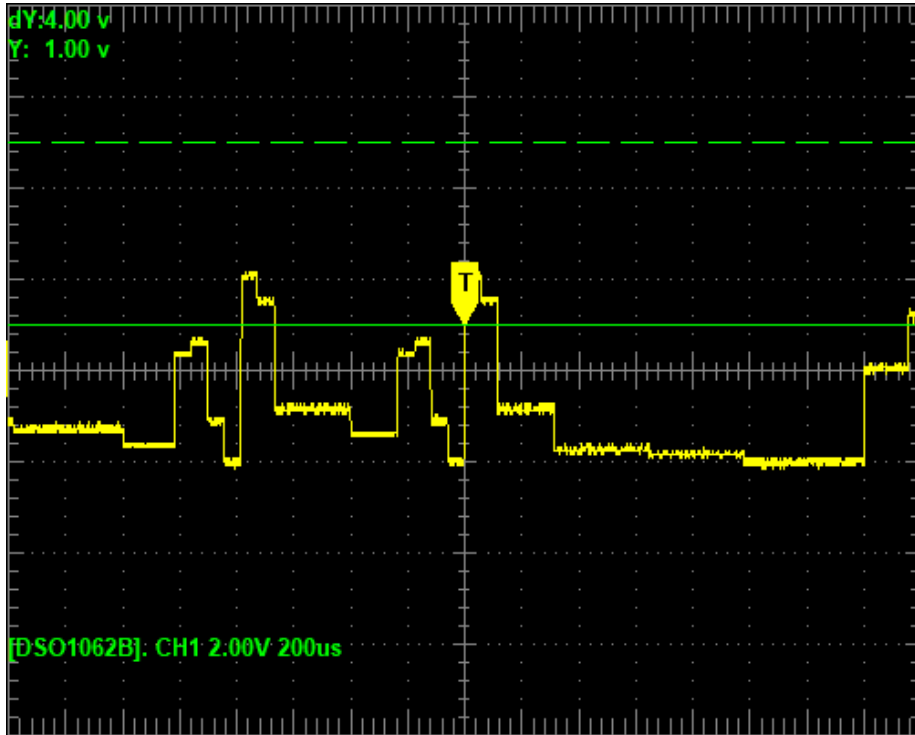

### 5.12.5 Pin 5 (Input)

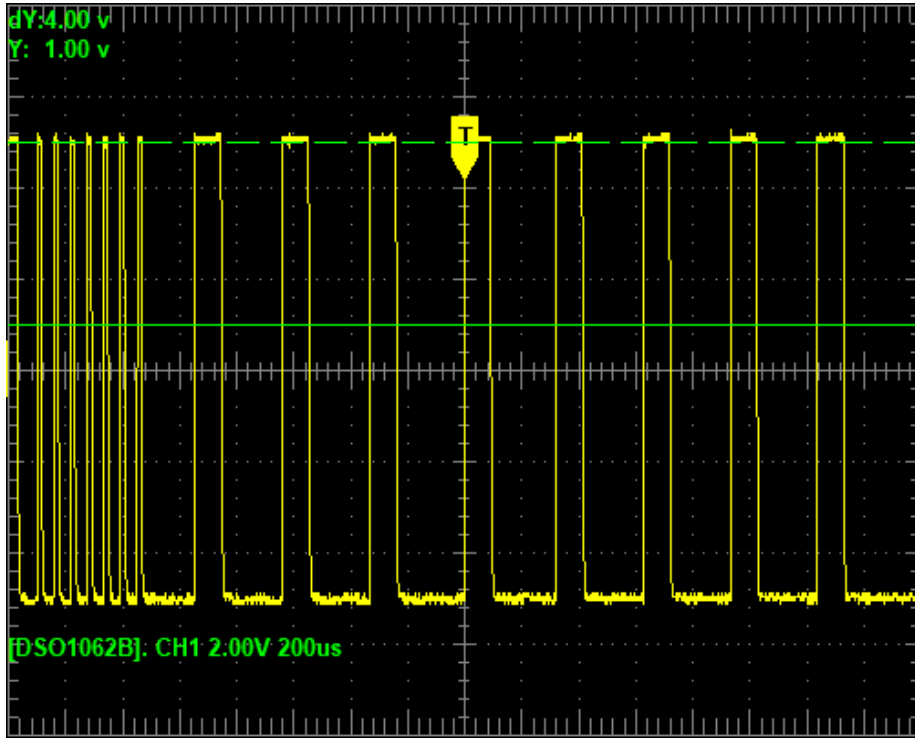

### 5.12.6 Pin 6 (Input)

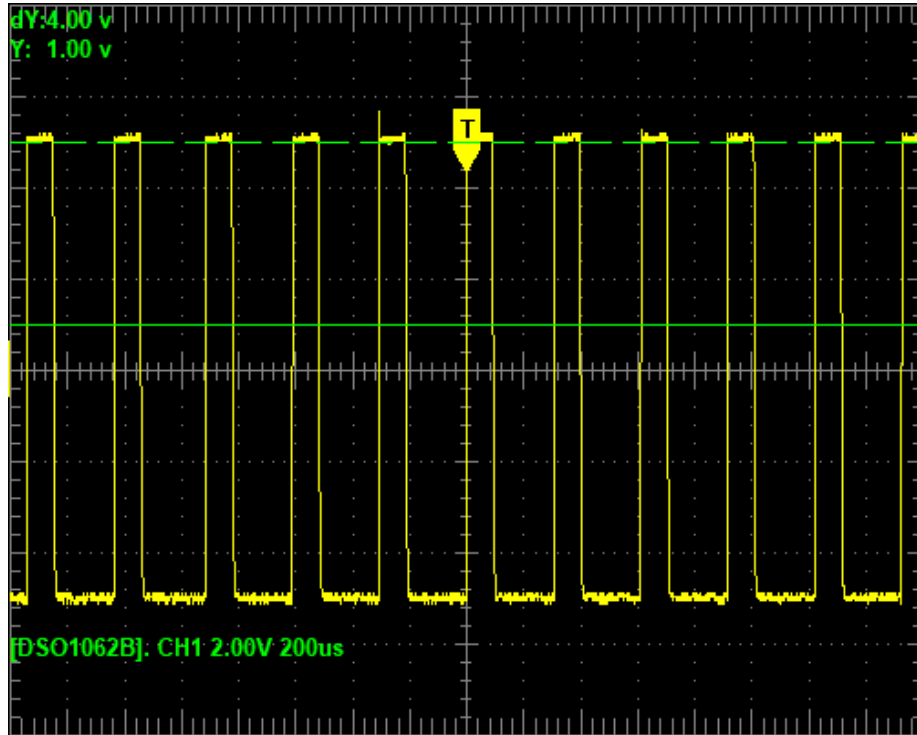

### 5.12.7 Pin 7 (VSS)

-5V analog

### 5.12.8 Pin 8 (Input)

See Pin 13 (Common X)



### 5.12.9 Pin 9 (Output)

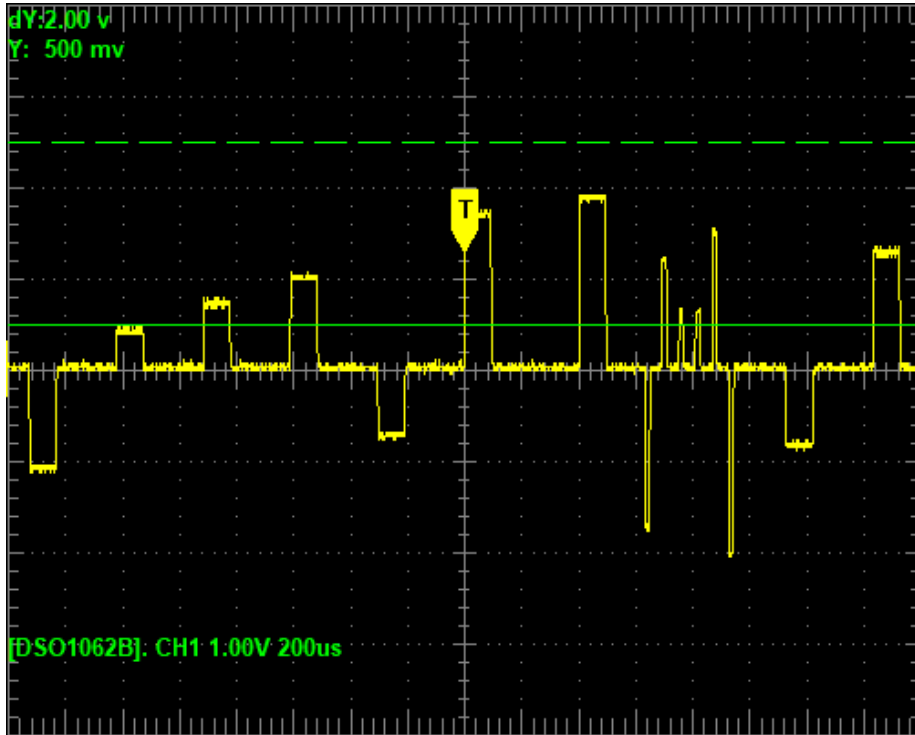

### 5.12.10 Pin 10 (Output)

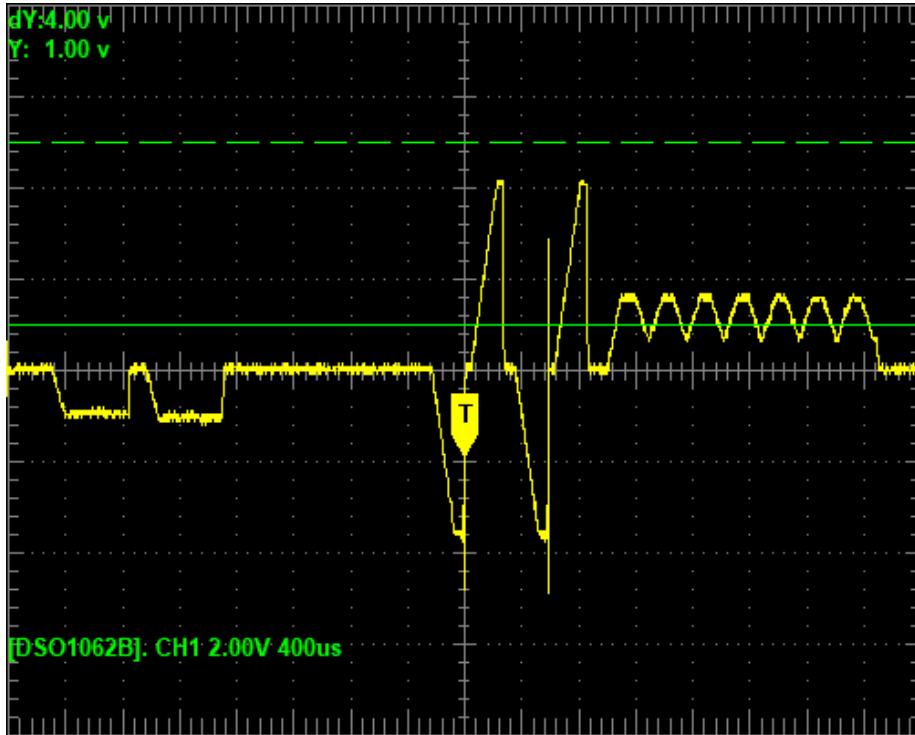

### 5.12.11 Pin 11 (Input)

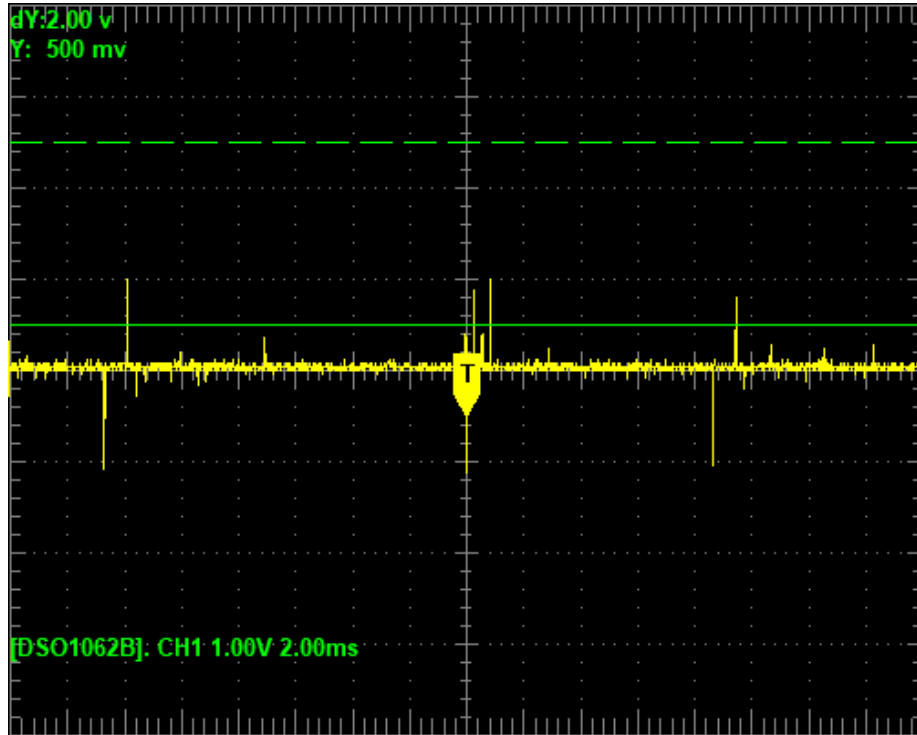

5.12.12 Pin 12 (Input)

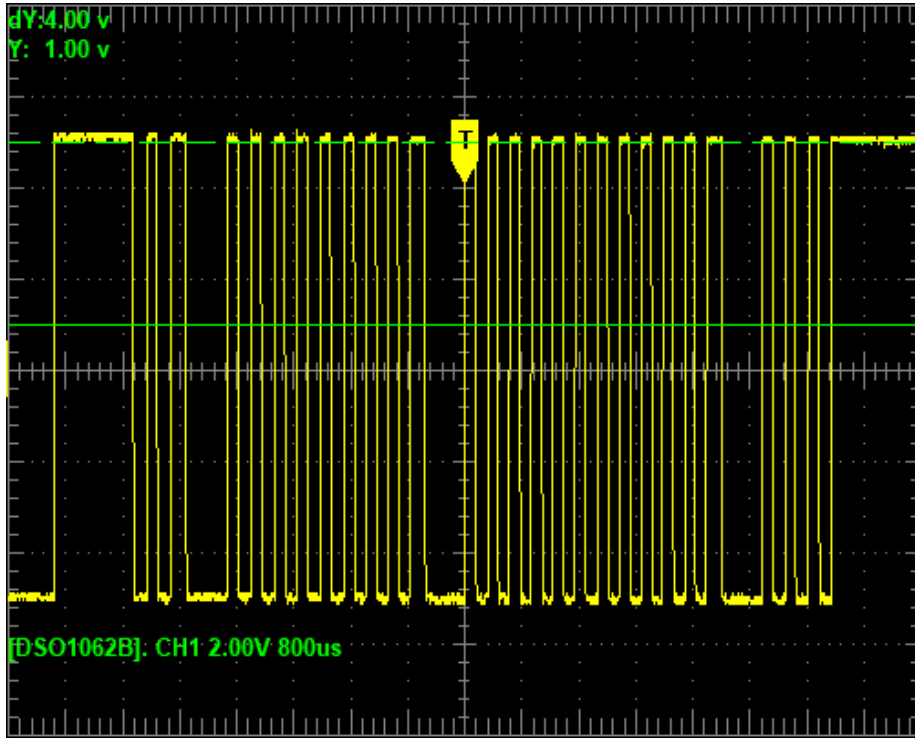

### 5.12.13 Pin 13 (Input)

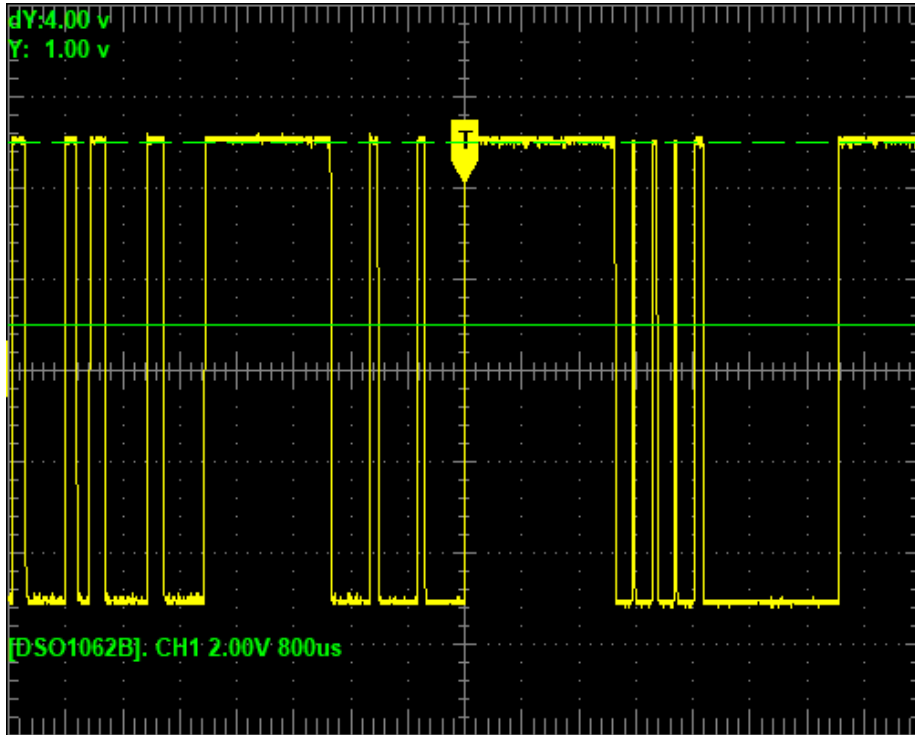

### 5.12.14 Pin 14 (VDD)

Power supply, +5V analog.

## 5.13 J301 - Video Connector

### 5.13.1 Blue

Output X of the video signal.

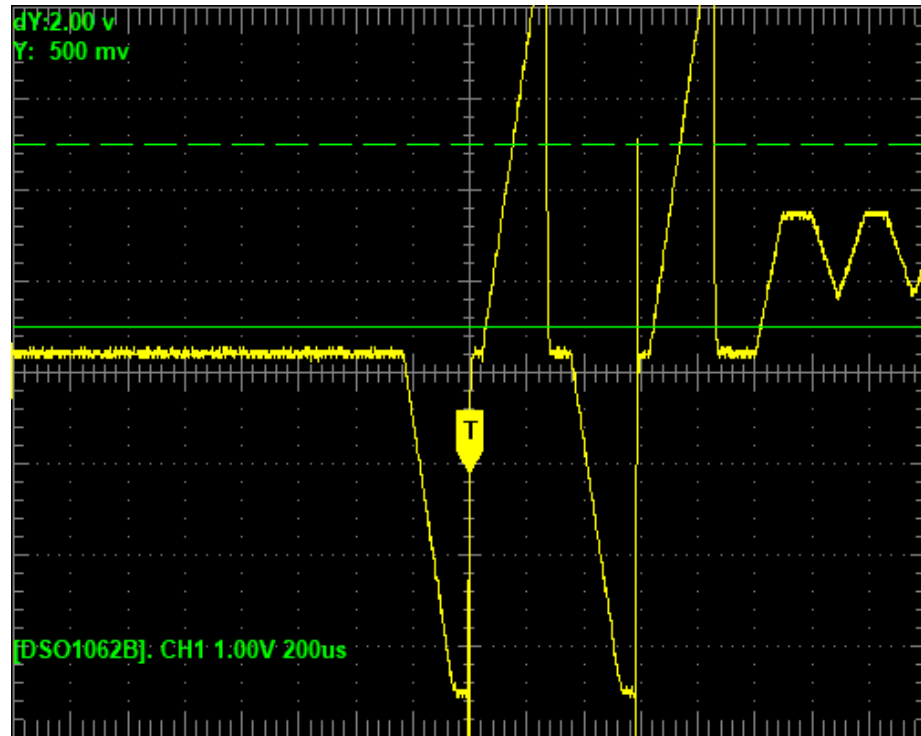

- If there is no signal, check R321. See IC305 Pin 10 (Output)

### 5.13.2 Red

Y output of the video signal.

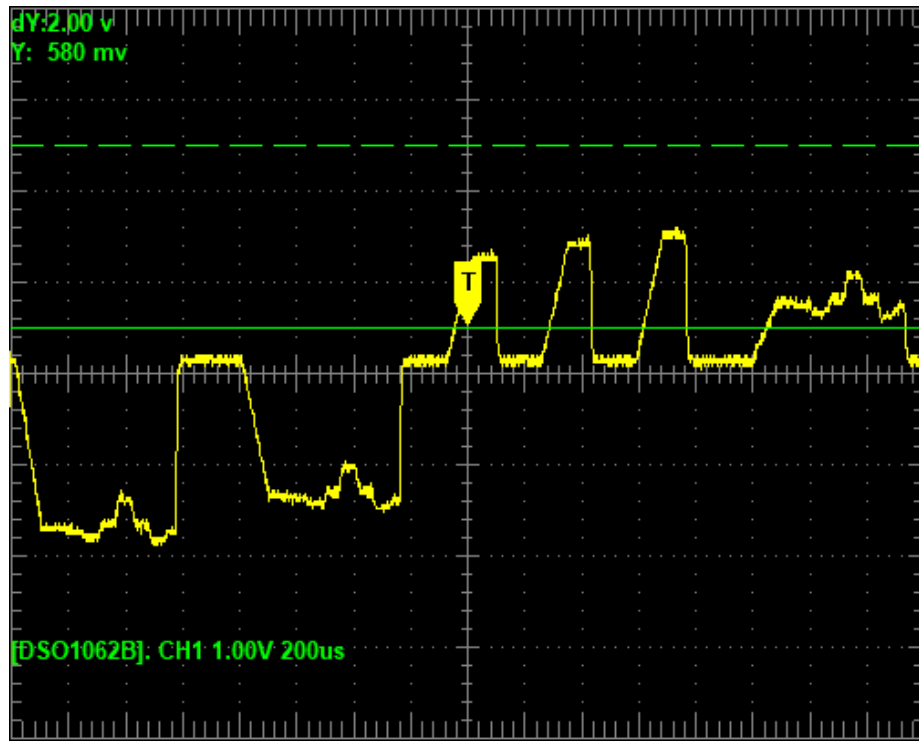

- If there is no signal, check R318. See IC305 Pin 2 (Output)

### 5.13.3 Yellow

Z output (light intensity) of the video signal.

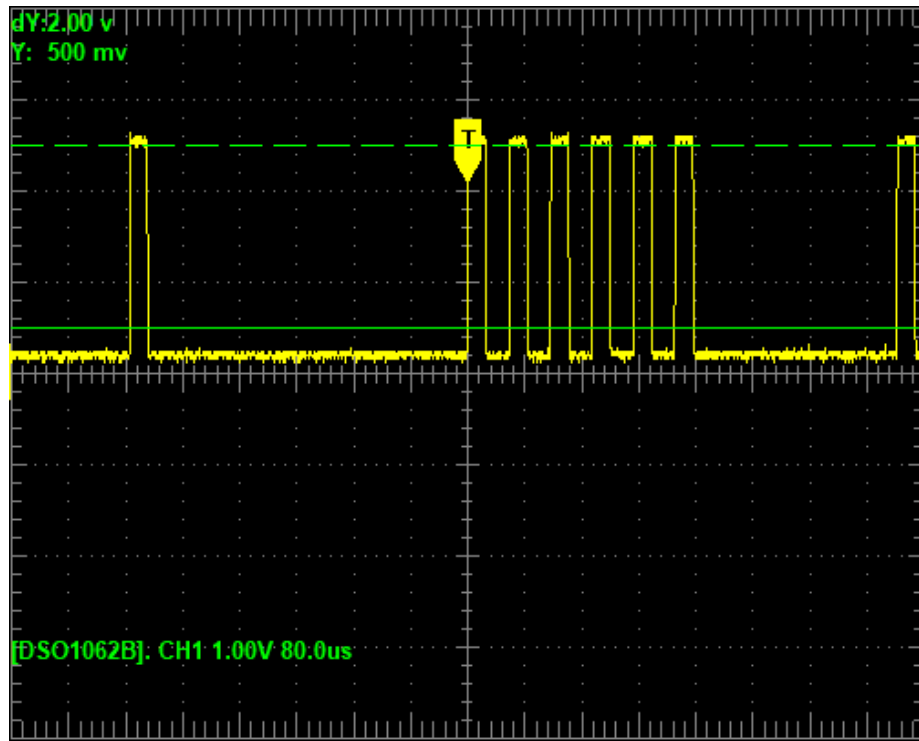

- If there is no signal, check R315 and D302. See IC207 Pin 19 (CB2).



## 5.14 J302 - Audio

### 5.14.1 Black

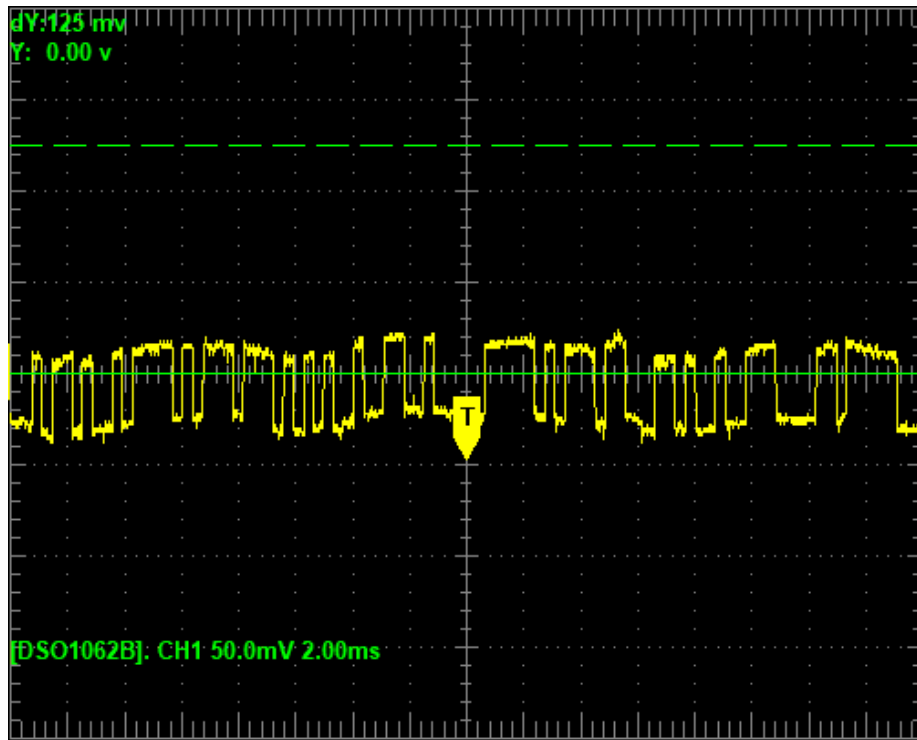

- If there is no signal, check the potentiometer/front panel volume switch R326. Check C323 and replace the audio generator (IC208) if necessary.

## 6 Technical documentation and substitute components

Reference	Name	Datasheet
IC101	LM340	<a href="https://www.ti.com/lit/gpn/lm340">https://www.ti.com/lit/gpn/lm340</a>
	LM7805	<a href="https://www.ti.com/lit/gpn/lm7800">https://www.ti.com/lit/gpn/lm7800</a>
IC102	LM7905	<a href="https://www.ti.com/lit/gpn/lm79">https://www.ti.com/lit/gpn/lm79</a>
IC103	LM386-3	<a href="https://www.ti.com/lit/ds/symlink/lm386.pdf">https://www.ti.com/lit/ds/symlink/lm386.pdf</a>
IC201	2363	
	284001-1	
	M27C64	<a href="https://www.mouser.fr/...cd00000519-1204359.pdf">https://www.mouser.fr/...cd00000519-1204359.pdf</a>
IC202	74LS00	<a href="https://www.ti.com/lit/ds/symlink/sn5400.pdf">https://www.ti.com/lit/ds/symlink/sn5400.pdf</a>
IC203	74LS32	<a href="https://www.ti.com/lit/ds/symlink/sn54ls32-sp.pdf">https://www.ti.com/lit/ds/symlink/sn54ls32-sp.pdf</a>
IC204	2114	<a href="https://hardware.speccy.org/datasheet/2114.pdf">https://hardware.speccy.org/datasheet/2114.pdf</a>
	TMM314AP	<a href="https://console5.com/techwiki/.../TMM314APL.pdf">https://console5.com/techwiki/.../TMM314APL.pdf</a>
IC205	2114	<a href="https://hardware.speccy.org/datasheet/2114.pdf">https://hardware.speccy.org/datasheet/2114.pdf</a>
	TMM314AP	<a href="https://console5.com/techwiki/.../TMM314APL.pdf">https://console5.com/techwiki/.../TMM314APL.pdf</a>
IC206	68A09	
IC207	6522A	
IC208	AY3-8912	<a href="https://console5.com/.../GI-AY-8910—AY-8912—AY-8913.pdf">https://console5.com/.../GI-AY-8910—AY-8912—AY-8913.pdf</a>
IC301	MC1408P8	
	DAC0808	<a href="https://www.ti.com/lit/ds/symlink/dac0808.pdf">https://www.ti.com/lit/ds/symlink/dac0808.pdf</a>
IC302	4052B	<a href="https://www.ti.com/lit/ds/symlink/cd4051b.pdf">https://www.ti.com/lit/ds/symlink/cd4051b.pdf</a>
IC303	LF347	<a href="https://www.ti.com/lit/ds/symlink/lf147.pdf">https://www.ti.com/lit/ds/symlink/lf147.pdf</a>
IC304	LF353	<a href="https://www.ti.com/lit/ds/symlink/lf353.pdf">https://www.ti.com/lit/ds/symlink/lf353.pdf</a>
IC305	4066B	<a href="https://www.ti.com/lit/ds/symlink/cd4066b-mil.pdf">https://www.ti.com/lit/ds/symlink/cd4066b-mil.pdf</a>
IC401	LM379	<a href="https://console5.com/techwiki/images/0/02/LM379.pdf">https://console5.com/techwiki/images/0/02/LM379.pdf</a>
IC501	LM555	<a href="https://www.ti.com/lit/gpn/lm555">https://www.ti.com/lit/gpn/lm555</a>
	NE555	<a href="https://www.ti.com/lit/gpn/ne555">https://www.ti.com/lit/gpn/ne555</a>